



Equipment for outdoor laser tag

NETRONIC platform

User's manual
Part 2
Additional equipment

Last update
30.11.2022

TABLE OF CONTENTS

1.	Remote control	3
1.1.	Access point selection	4
1.2.	Configuring game kits	5
1.3.	Managing the autonomous operation of a headband or a vest	6
1.4.	Configuring and controlling additional devices	6
1.5.	Controlling the game using the remote control	7
1.6.	Setting the button commands	7
2.	Smart mini remote control	10
2.1.	Setting the buttons with the remote control	10
3.	Domination Box Smart	11
3.1.	Setting and controlling the Domination Box using the remote control	12
3.2.	Game modes	13
3.3.	Access point selection	15
4.	SIRIUS Station	16
4.1.	Setting up a station with the remote control	16
4.2.	Game modes	18
4.3.	System mode	23
5.	Multistation	26
5.1.	Game modes	27
5.2.	System mode	31
6.	Supernova laser tag bomb	32
6.1.	Using the Bomb in laser tag games	34
6.2.	Bomb planting	35
6.3.	Bomb clearance	36
6.4.	Algorithm for using a laser tag bomb controlled with the Remote Control and with default settings	37
6.5.	Service mode	39
7.	Wi-Fi Router	42
7.1.	Setting the router in case of accidental reset	43
8.	Portable power supply for the router	46
8.1.	The procedure for connecting to the router	47
8.2.	Charging the power supply	47
9.	Charger 1A	48
10.	Charger 2A	49
11.	Charger VORTEX	50
12.	Electronic shooting range	51
13.	Trip-wire mine	52
14.	Electronic grenade	54
15.	Safety procedures	55

The main component of laser tag game equipment are the kits that consist of a blaster and hit-capturing devices (a headband and/or a vest). But for conducting full-fledged games you need additional equipment. To configure and control the kits, you need the remote control, and a router that provides communication with the server. The batteries built into the equipment are charged with chargers. In addition, for a variety of scenarios in the game, you can use the Domination box, SIRIUS Station, Multistation, Bomb and various electronic simulators.

This manual is relevant for equipment with the following minimum firmware numbers for equipment microcontrollers:

- laser tag gun - 19.4.9257
- headband/vest – 5.2
- shock-band Scorpion – 6.1
- SIRIUS – 5.1.15
- Multistation – 5.3.15
- Smart Domination box – 4.4.56
- Supernova laser tag bomb – 1.9

1. Remote Control

The smart remote control (Remote Control) is designed to change the parameters of the laser tag gun, configure additional devices and control the laser tag game.

Power: 2 batteries for 1,5 V of the AAA type.

On the external panel of the remote control there are 18 buttons, graphically divided into 4 zones: assigning the color of the teams, game control, presets (scenario settings of the Game kits) and functional buttons. The front side panel of the remote control is made of a material transparent to IR-radiation, that allows you to send and receive game commands.



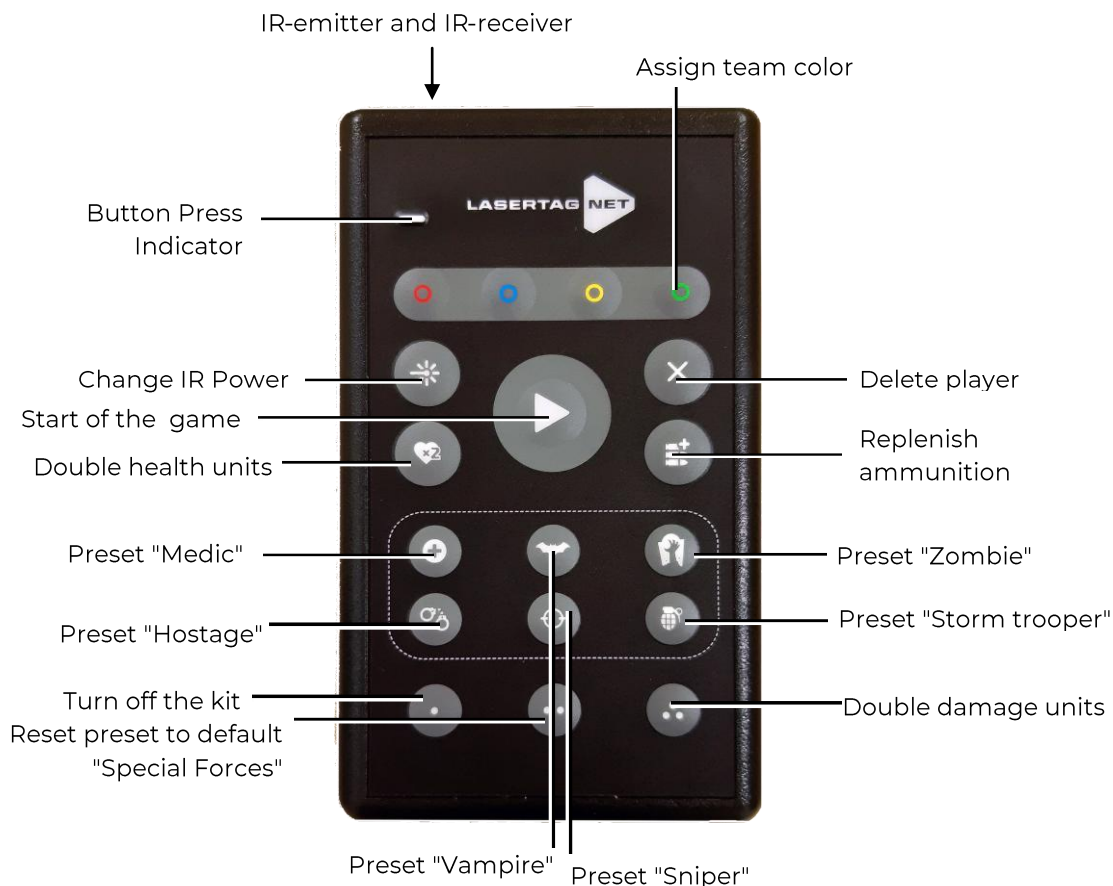

External elements of the remote control

1.1. Access point selection

In case of simultaneous use of game kits at two or more playgrounds, and with several access points configured for different names, it is necessary to configure the kits for the corresponding names. To do this you need to:

1. Switch on the blaster in service mode (pushing the trigger) and turn on the headband (vest).
2. Directing the emitter of the remote control at the headband or infrared receiver of the blaster, press one of the preset buttons corresponding to the name of the access point

- LASERTAG (LT), - LASERTAG-NET (LN), - MGO (MG),
 - Test mode (TM), - OTK (OT), - TechSupport (TS);

LEDs on the headband respond by double blinking with the color of the team, and you will also hear the sound effect of a passing bullet. The full name of the access point will be displayed on the laser tag gun screen.



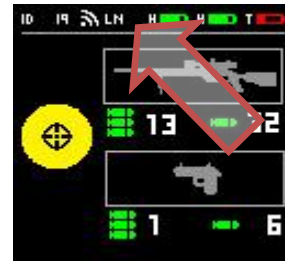









3. Turn the kit off and turn it on again in standby mode.
Two letters of the abbreviated name of the access point should appear in the top line of the laser tag gun screen, next to the Wi-Fi connection icon.



Laser tag gun screen when selecting an access point

1.2. Configuring game kits

To change the settings of the kit, the laser tag gun, the headband and/or vest (hit capture device) must be located within the direct line of sight from the remote control, optimally no further than 5 meters:

1. Switch on the laser tag gun and the headband in standby mode. If the kit is correctly attached, the headband will blink in the previously selected team color and you will hear a system sound.
2. Point the IR emitter of the remote control at any of sensors on the headband or tager.
3. The color of the team can be changed using 4 buttons "Assign team colors"     pressing the button with the selected color, the color of the RGB indicators of the headband and the power indicator of the blaster change, accompanied by a short sound signal from the speaker of the tager.
4. To change the power of the beam emitted by the infrared diode on the blaster, you must push the "IR beam power" button. . This parameter varies depending on the conditions of the game: in open areas, in sunny weather, the beam power must be increased, in the evening, indoors to decrease the rebound effect, it must be reduced. The remote control allows you to switch two gradations of power (maximum or minimum), which will change each time the button is pressed. The factory settings of maximum power correspond to 90 conventional units, and minimum - 40. In the first case, the tager speaker reproduces the sound of a shot from a space blaster, with reduced power - the standard sound of a shot. At the same time, the range of the shot and the brightness of the glow of the optical LED will change. Setting the maximum or minimum power of the infrared beam with an accuracy of 1% can be done using the program installed on a phone (tablet).
5. To increase the number of player's health units in this round of the game, you must click the "Double health units" button . And each press will double the previous value, up to 255 units. In this case, the blaster will play sound signals resembling Morse code.
6. The button on the remote control  allows you to replenish ammunition, and the tager's magazine is refilled, i.e. if at that moment there were 29 rounds left in the magazine, then only 1 round would be added (with the settings of 30 rounds in the magazine).
7. There are 6 preset buttons that allow you to quickly change the settings of kits depending on the scenario. Each preset is a pack of settings that allows you to give the kit specific, different from standard abilities. The remote control allows you to assign such presets: Doctor , Vampire , Zombie , Hostage , Sniper and Stormtrooper . To reset to the standard settings of the kit ("Special Forces"), press the button with two dots .

The remote assigns presets with pre-configured parameters (a chart with the basic settings of presets is given in chapter 1.2.1. Part 1 of this manual), but starting from the version 2.02 of Lasertag Operator (for Android), it is possible to edit presets. However, custom settings are applied only when connecting kits to the server. Therefore, if the kit is online, when the preset is sent with the remote control, the parameters set in the program are assigned, if the game is played without a server, the default settings are used.



8. Buttons with dots are functional, i.e. the user can assign commands to them (as to any other button). But in the factory settings there are also default commands installed for these buttons.

So, a button with one dot  allows you to turn off the kit. To do this, direct the emitter of the remote control at the infrared sensor of the tager or hit capture device, and then press this button.

“Reset to the default preset” command is installed on the a button with two dots .

Pressing a button with three dots  doubles the damage caused by shot.





You can change the power of the shot, the number of lives, the color of the team, double the damage of the kit, and you can inflict 2 damage during the game round. You can also turn off the kit during the game.

9. To change the volume level of the blaster speaker, put it in service mode (by holding down the trigger). Directing the remote control at the IR receivers of the kit, and pressing the buttons Change IR Power  (increase) and Double Health Units  (decrease) you can set the required level.

1.3. Managing the autonomous operation of a headband or a vest

Starting with firmware version 19.2, the headband and vest can function autonomously, without a blaster. Because there is no Wi-Fi module in the control board of the hit capture device, and there is no way to connect to the network, configuration and control are carried out only by using the Remote Control.

To activate an autonomous mode, it is enough to turn on the headband or vest, direct the transmitter emitter at the sensors and press one of the preset buttons.

At the moment, 5 battery life modes are implemented: Activator (button ), Medic (), Zombie Player (), Frontier, () and Hostage (.

To start the modes, you must click the Start Game button .

The description of the autonomous operation modes of the hit capture device is described in Chapter 2.7. part 1 of this manual.

1.4. Configuring and controlling additional devices

Using the remote control, you can configure and control devices such as Smart Domination box and SIRIUS Station.

Just like with game kits, it is possible to select the name of the access point.

More details on controlling additional devices using the remote control are described in the corresponding sections of this manual.

1.5. Controlling the game using the remote control

The use of the equipment manufactured by the company implies the use of a Wi-Fi network. In this case, the functionality of both game kits and additional equipment will be fully disclosed. But games can be held using only the remote control.

After setting up the game kits (team color, preset, IR beam power, additional health units - see Chapter 1.2. Of this manual), you can start the round. To do this, you need to point the IR emitter of the remote control at the sensors of the headbands / vests of the players (in direct visibility up to 5 meters) and press the Start the game button .

At the same time, all the headbands respond with a short flash of the team color, and the speakers of the tagers reproduce the sound "Go, go, go!" or "Start!".

The teams go back to the bases and wait for the start sound signal.

During the game the referee can remove the player, for example, who violated the rules using the remote control, To do this, you must direct the IR emitter of the remote control at the headband of this player and press the Delete Player button .

With the Start the game button , the referee can restore the player in the game, without his returning to the base.

1.6. Setting the button commands

By default, the remote control is already programmed to execute all the necessary commands, but any button can be reprogrammed to your own desires and needs of the game. There are two ways to do this - copying and self-programming.

To copy, you need a similar remote control, the commands of which can be duplicated. The procedure is as follows:

1. Place the remote control with the front translucent panel in the direction of the emitter of the copied remote control (face to face).
2. Press the button you want to reprogram on the remote control until the button indicator flashes rapidly.
3. While holding this button down, press the necessary button on the remote control that is being copied. Successful receipt of the pack will be displayed by increasing the flashing frequency of the indicator of the remote control that is being programmed.
4. Wait until the indicator goes off and release the button.
5. Check the correctness of the change.
6. Repeat the procedure for other buttons if necessary.

In addition, the remote control can "self-adjust". Using the buttons as a keyboard and typing the command code, you can program each of them (except for the button Change color to red) without additional devices.

The programming procedure is as follows:

1. Simultaneously press the Change color to red button and the button that needs to be reprogrammed.
2. Wait until the flashing green LED first increases the frequency, and then stops (should constantly glow).
3. While holding the Change color to red button, release the button that is being programmed.
4. Without releasing the Change color to red button, dial a 4-digit code, according to the code chart and the attached scheme of buttons and symbols.

! The coding of the remote control buttons of the new type is different from the old version.

In order to familiarize yourself with the codes on the old remote, you need to refer to the “Netronic platform equipment user manual for working with WiFi router”. You can find it here: <https://lasertag.net/manuals/>



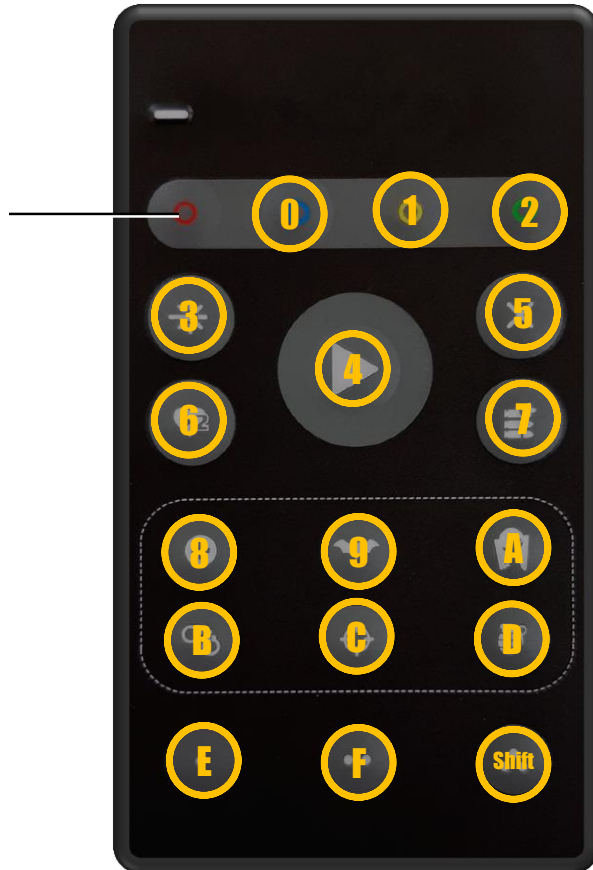

“Change color to red” button



The scheme of correspondence of buttons and symbols of the remote control

5. When the button is pressed correctly, the LED should temporarily turn off.
6. The green LED will turn off as a confirmation of a successful code entry.
7. Check the correctness of the change.
8. Repeat the procedure for other buttons if necessary.

If necessary, return to the default settings, just hold the buttons of the Hostage  and Stormtrooper  presets for 5 seconds. You should wait until the frequent blinking of the green LED stops and turns off, this action restores the factory settings.

Codes table

Remote Button	Symbol	Command	Code	Set
		Change the team color to red	A900	
	0	Change the team color to blue	A901	
	1	Change the team color to yellow	A902	
	2	Change the team color to green	A903	
	3	Change IR Power	830E	
	4	New game	8305	
	5	Delete the player	8300	
	6	Double health units	8310	
	7	Add ammo to the magazine	811E	
	8	Medic preset	A806	
	9	Vampire preset	A807	
	A	Zombie preset	A803	
	B	Hostage preset	A801	
	C	Sniper preset	A805	
	D	Stormtrooper preset	A800	
	E	Turn off the kit	EOE0	
	F	"Special Forces" preset (default)	A804	
	Shift	Double damage inflicted by kit	8312	
		Change the team color	8309	
		Add 1 point of health	8B01	
		Respawn	8304	
		Radiation	A001	
		Domination box captured	8311	
		Radiation only for red	BE01	
		Radiation only for blue	BF01	
		Radiation only for yellow	C001	
		Radiation only for green	C101	



2. Smart mini remote control

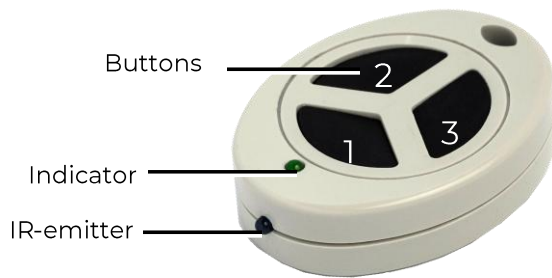

The external view of the remote control and the numbering of buttons

The smart mini remote is a simplified three-button version of the remote control. By default, the buttons are programmed to execute the following commands: № 1 - "New Game", № 2 - "Change Team Color" and № 3 - "Double Number of Lives".

Power supply: battery type CR 2032.

It is easy to use remote control smart mini - to click the necessary button having pointed at the sensors of the selected player. The green LED indicator meanwhile should light up. The range of the remote control IR emitter operation is 3-5 meters

As well as the remote control, the Smart mini remote control is a "learner", i.e. Each button can be assigned with any protocol command. This opens up wide scope both for creating the optimal device for the instructor, and for using this device in scenario games.

Commands for the remote control buttons can be assigned by copying of commands for standard remote control.

The device's case is particularly transparent for infrared radiation, therefore the buttons can be programmed without disassembling the case. IR-receiver is located on the back of the remote control from the buttons.

2.1. Setting the buttons with the remote control

1. Set the adjustable button of the mini-remote to the programming mode: hold the button for about 5 sec and wait until the light of the indicator starts blinking.
2. While holding the button down, point the IR emitter of the remote control at the back of the body and press the selected button. The assignment of a new command will be indicated with LEDs flashing on the mini remote control (approximately once per 1 sec).
3. After releasing the button, the next time you press the Smart button on the mini remote control will be with the new protocol command.



3. Domination box Smart

Domination box Smart is an indispensable attribute of many scenario games in laser tag.

The mission of the Domination box is to registrate its “captures” by players from different teams, sum up the total time the team was in control, or the number of shots made to DBs receiver, and then determine the winner. Capture is made by an infrared ray pulse directed from the laser tag gun into the sensor. The sensor is placed in the lower inner part of the device, so the emitter must be placed vertically downward relative to the base plane of the Domination box. It has to do with the fact that the IR receiver is located at the bottom of the body of the domination box. This arrangement of the sensor eliminates long-range captures.

One of the advantages of this device are the indicator columns, which clearly show the degree of capture of each team. You can also use 5 different game modes to capture the domination box in time or by shots.



DB Smart

The device consists of a stand and a case, on the outside of which there are three racks with 16 LEDs in each. On the case itself, there is a connector for the charger, a service button and a power button. Three IR-emitters are mounted on the top cover, another 3 are mounted in the upper part of the case on three sides, providing a circular effect on the kits of players. There is an electronic board with an infrared receiver, a speaker and batteries inside the case.

The device is configured and controlled both by the remote control and via computer programs.

Switching on, the domination box searches for the access point to the server. If the device connects to the server, the central four LEDs on each of the indicator columns begin to glow with different colors and the control goes to the computer program. If the access point is not found or the server is not used in the game, the two central LEDs light up in the

mode in which the device was used before shutting down. In this case, the control and adjustment is performed by the remote control.











3.1. Setting and controlling the Domination Box using the remote control

The DB has 3 operating modes: setup, game mode and firmware update mode.

In the setup mode, as well as in the game mode, it is possible to find out the battery charge level. To do this, press and release the service button. The number of violet LEDs glowing will indicate the battery charge: 16 LEDs - 100%, 8 - 50%, 1 - 10%, etc.

The setup mode is used to select and configure the game modes of the Smart Domination box.

There are 5 game modes. Each of them corresponds to a certain color (Mode icons and colors are indicated on a sticker placed on the device body):



Nº	Name	Icon	Capture	Preset Button on the Remote Control	LED color during setup
1.	Capture by time		By time		White
2.	Capture by shots		By shots		Yellow
3.	Tug of war		By time		Red
4.	Triple capture		By time		Green
5.	Flag raising		By shots		Blue



There are two ways to activate the setup mode. The first is to point the emitter of the remote control at the domination box receiver and press the preset button.

The upper and lower LEDs of the indicator columns will glow in the color of the mode, and the middle 10 will show its current settings (capture time or number of shots).

In the shot capture mode, the light of one LED corresponds to 50 shots, 2 LEDs - 100, 3 - 150, 4 - 200, 5 - 250, 6 - 300, 7 - 350, 8 - 400, 9 - 450, 10 - 500.

In the capture by time mode, the light of one LED corresponds to 1 minute, 2 LEDs - 2 minutes, 3 - 3 minutes, 4 - 4 minutes, 5 - 5 minutes, 6 - 7 minutes, 7 - 10 minutes, 8 - 15 minutes, 9 - 20 minutes, 10 - 30 minutes.

To change the settings and configure the desired parameters, use the buttons Delete  (more) or Refill ammunition  (less).

In the setup mode you can also cyclically change the game mode by pressing the IR beam power button . By pressing the Double health units button  the modes change in the reversed order.

The other way to activate the setup mode is to hold the service button for 3-4 seconds. After that the current mode will be displayed. If the LEDs glow in red, and only four out of ten center ones are lit, this means that the device is configured for the "Tug of War" game with a hold time of 4 minutes.

This method is convenient if the instructor has a remote control without preset buttons. It can be the Smart mini remote control, the buttons of which are programmed into three commands: "Start the game", "Change the power of the IR beam" (select the game mode) and "Delete the player" (mode setting). This will be enough to control the Domination box. (See paragraph 2.1. of this instruction).

To switch to the game mode, it is necessary to direct the emitter of the remote control at the Smart receiver and press the Start the game button . After that, only the upper row of LEDs remain glowing in neutral white (to facilitate the search of the device at the start), and the player hears the command "Go, go, go!" from the device's speaker.

When the team captures for the first time or re-captures the Domination Box, the message "Domination Box is Captured" sounds, which is duplicated by the speakers of the laser tag guns of the kits located in the zone of influence of the DB IR-emitters.

3.2. Game modes

3.2.1. Time Capture Mode of Domination box Smart.



2 to 4 teams are participating.

This is a classic mode. At the first shot at the DB sensor, the lower LEDs of all indicator posts are lit by the color of the team of the hit player and the timer of the captured team starts. If at the same time there is no interception by another team, the LEDs will be lit sequentially from the bottom upwards and will show the capture level. The glow of each LED corresponds to 1/16 of the set hold time.

When the box is captured by another team, the timer of the new team starts. The LED strip begins to show the capture level in the relevant color. The timer of the previous team stops and does not reset, but resumes its work after the first team again captures the Domination Box.

After the timer of one of the teams participating in the round reaches the set time (all 16 LEDs light up), the victory is assigned to this team. The Domination Box plays an audible signal and flashes the color of the winning team.

To resume the round with the previous settings, it is necessary to direct the emitter of the remote control at the domination box receiver and press the button Start the game.

3.2.2. Shot Capture Mode of Domination box Smart.



2 to 4 teams are participating.

It differs from the previous mode in that the capture does not take place in terms of retention time, but in the number of shots fired by players at the DB receiver. Also, so that players do not linger near the Domination Box, during the game according to this scenario, the device constantly sends out the protocol command "Radiation". At the same time, after the time set in the program, players in the zone of influence of the IR-emitters of the device will be taken away health units.

At the first hit, the lower LEDs of all racks are lit with the color of the player's team. On next hits, the LEDs will sequentially fill the racks from the bottom up to a multiple of the set capture value. For example, if the setting value is set to 100 hits, then the ignition of each LED will correspond to $100/16 = 6$ hits.

When players of other teams enter the DB receiver, the LEDs will show the degree of capture by these teams in the appropriate color. At the same time, the achieved level of the remaining teams is not reset.

When a team reaches the set value of hits, the Domination Box plays a audible signal and starts blinking in the color of the winning team.

3.2.3. Tug of War Mode.



2 teams are participating. Time capture.

A specific feature of the mode - the indication of the degree of capture is made for two teams in real time on all three indicator rack.

When a point is captured by the first team, its timer is activated and the lower 8 LEDs immediately are lit with the color of this team. At the same time, they pulsate and until the point is captured by another team, the glow gradually rises from the middle up. The second team ignites the upper part of the rack with its hit, and now the indicators of its color will “shift down” the LEDs of the second team. The glow of each LED corresponds to 1/16 of the set hold time.

When all the LEDs are lit in the same color, the Domination Box plays an audible signal and starts blinking in the color of the winning team.

3.2.4. Triple capture Mode



2 to 3 teams are participating. Time capture.

A specific feature of the mode - the indication of the degree of capture of the Domination Box is made in real time for each of the teams in different indicator stands.

After the first hit, the timer of the capturing team is turned on, and the lower LED of one of the indicator racks starts to flash smoothly with the color of this team. As the timer works, the LEDs will light up from bottom up, each of which will correspond to 1/16 of the set hold time. After a player hits another team, they start to light up and flash the LEDs of the second indicator rack from bottom to top. The timer of the previous team stops and does not reset, but resumes its work after this team again captures the Domination Box. The LEDs of this rack stop flashing and remain lit at the achieved level. It similarly occurs after hitting the third team. The DB does not respond to the fourth team.

After all the LEDs of one of the indicator racks light up, the Domination Box plays an audio signal and starts flashing with the color of the winning team.

You can use this mode for two teams as well, but you need to set the Domination Box so that the racks of both participating teams are visible, for example, near a wall.

3.2.5. Flag Raising Mode.



Two teams are participating. Capture by shots.

A specific feature of the mode - the capture is carried out by shots, and the indication of the degree of capture is carried out simultaneously on all indicator racks on the basis of the “flag raising” principle.

After the first shot, the lower LEDs of all three racks are lit with the color of the player's team. When the number of shots is equal to 1/16 of the set capture parameter, the LEDs light

up sequentially. If the second team makes a “re-capture”, then first the LEDs of the color of the previous team will go out sequentially (the flag of the first team “drops”), and then they will light up with the color of the newly captured team (the flag of the second team is “raised”).

Also, as in the Capture by shots mode, during the game the IR-emitters of the device by default issue the Radiation command, and players who are in the zone of influence of the emitters will be taken health units.

The winner is the team that first "raises" the flag / LED strip of its color. The Domination Box plays an audible signal and flashes the color of the winning team.

3.3. Access point selection



If it is necessary to simultaneously use game sets on two or more platforms, the corresponding number of access points with different names is set. All the kits and additional devices participating in the game on one platform must be connected to the same point.

To connect the Smart domination box to a specific point, it is necessary to direct the emitter of the remote control at the receiver of the domination box and press the Sniper preset button .

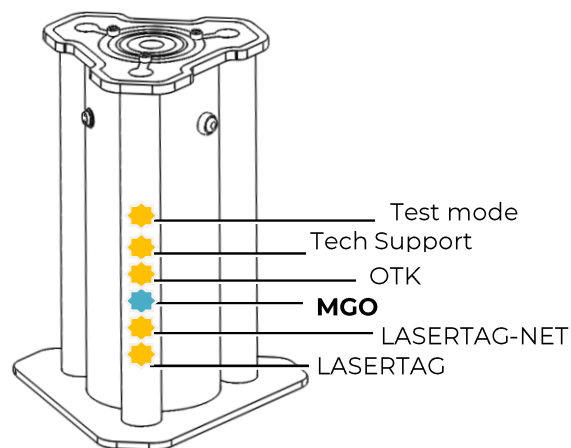



6 central LEDs will light up on one of the indicator columns, one of them will flash in blue, and the rest will glow in yellow. A flashing LED indicates which access point the device is connected to:



Indication when connecting to the "MGO" access point «MGO»

To change the access point, you have to use the Delete the Player  (up) and Refill Ammunition  (down) buttons on the remote control.

Another way to change the access point is through the setup mode (in standby mode, hold down the service button for 3-4 seconds).

First, the purple indicators show the battery level, and then the ones last in the row and 10 central ones show the current mode and its setting. Next, you need to sequentially click the buttons Change IR beam power  (forward) or Double health units  (back). Choose the access point selection mode when 6 central LEDs show the name of the current point. Next, use the remote control buttons  and  set the name.

To confirm the change of the access point, press the Start Game button  on the remote control and the game mode will be set on the domination box



Configuring and managing the Smart Domination box with computer programs is described in part 3 of this manual.

4. SIRIUS Station

The SIRIUS station is an additional device that, thanks to its capabilities, allows you to create a huge number of interesting laser tag scenarios. Distinctive features of the station are 8 game modes, an indicator panel, a touch sensor and a futuristic case with side backlight.



Station SIRIUS

Power supply: 220 V network via a power supply unit (8.4 V 1 A) or a built-in 7.4 V 2600 mAh battery. Sound: buzzer.

The device's activation (impact on the player's sets) is done in three ways, depending on the mode: by shooting the device (Bonus and Flag mode), automatically by timer (other modes) and compulsory: when a palm covers a sensor for a short time, the touch sensor is activated (Med kit, Respawn and Arsenal).

The range of infrared emitters with a direct line of sight is 5-7 meters.

The device is configured and controlled with the remote control, and also via the computer program Lasertag Operator for Android.

In the current release, the station can operate in the following 8 modes: Respawn, Radiation, Med Kit, Arsenal, Random, Base and Bonus and Flag.

4.1. Setting up a station with the remote control

The SIRIUS station is configured with the remote control when playing games without server support, or if operational control of the device is necessary. You can select the mode of operation, the teams that affected by the device when it is active, a pause between these effects.

To change the settings you need to:

1. Turn on the device. The station immediately switches on in the same mode and with the same settings in which it worked before shutting down.
2. Direct the emitter of the remote control at the SIRIUS receiver (it is located in the center of the LED panel).

- By pressing the buttons on the remote control, select the desired mode, which teams to affect and with what frequency.

The selection of a mode is carried out in two ways:

- directly;
- cycling through

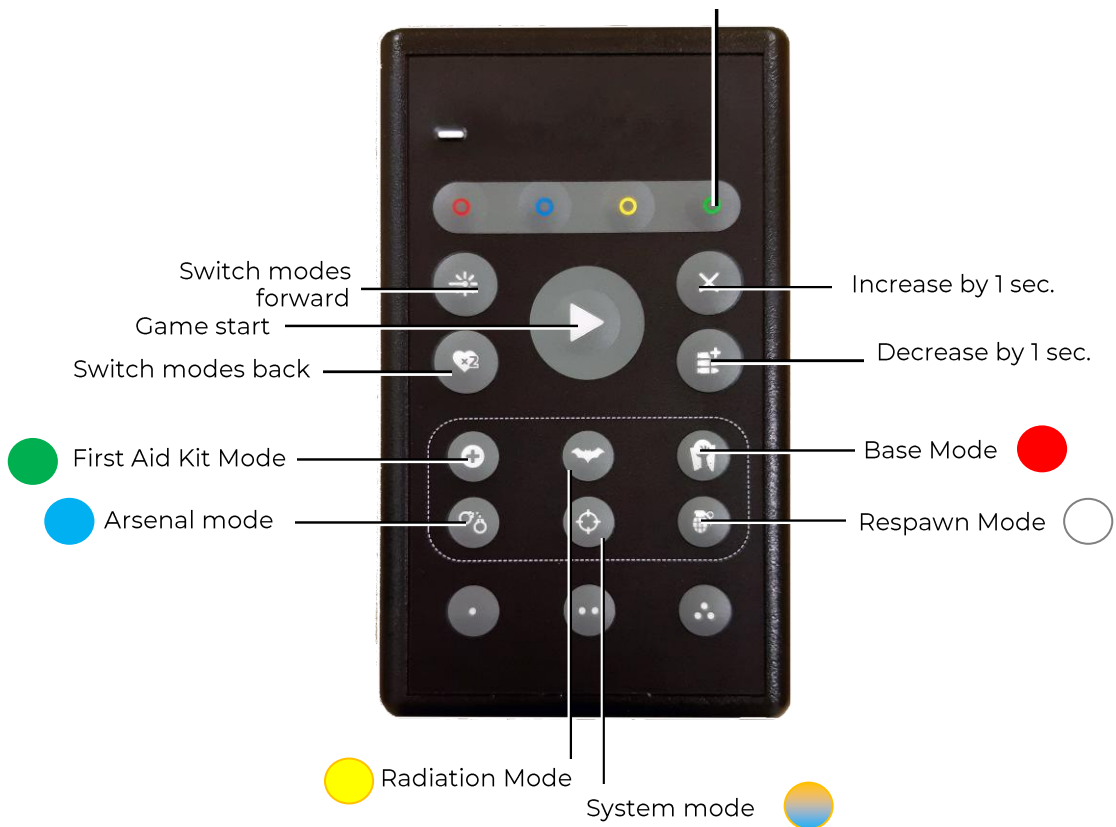

Direct connection can be assigned to 6 out of 8 game modes (except for the Random, Bonus and Flag modes). To do this, direct the emitter of the Remote Control at the SIRIUS receiver and press the preset button corresponding to the mode (see figure):

Team color assignment



Functions of the remote control buttons when configuring in the SIRIUS Station

Cycling through the modes goes as follows:

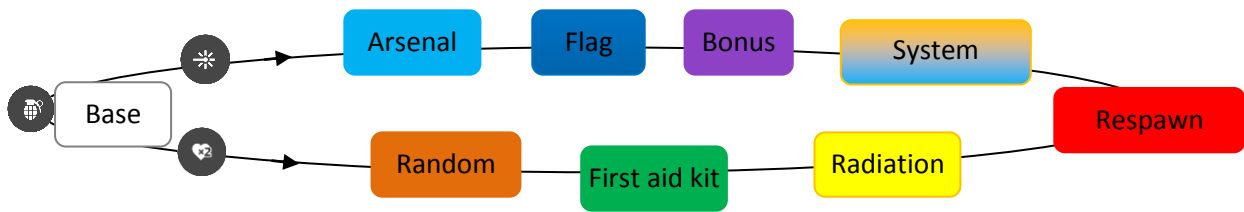

- Direct the remote control emitter at the SIRIUS receiver
- Press any preset button on the remote control (preferably Stormtrooper) .
- Based on the color of the glow of the outer ring of the LEDs, use the buttons Change IR beam power  (forward) and Double health units  (back) to select the desired mode.

During setup, each of the modes corresponds to a certain color of the LEDs on the outer ring of the LED panel.



Sequence of modes during item-by-item selection with the remote control

The number of lit LEDs on this ring corresponds to the time in seconds of a pause between the device activity.

You can configure the timer using the remote control: the Refill Ammunition button  increases the time by 1 second, the Delete Player button  decreases it by 1 second. The remote control can set the time from 1 to 8 seconds, but via the program it is possible to set a pause of up to 254 seconds.

The color of the central 4 LEDs will indicate the color of the team the device is affecting. You can change the color by pressing the buttons on the Assign the team color panel. If you repeatedly click on the button of the current color or double-click any other button to assign a color, the device will affect everyone. In this case, the central LEDs will glow in 4 colors.

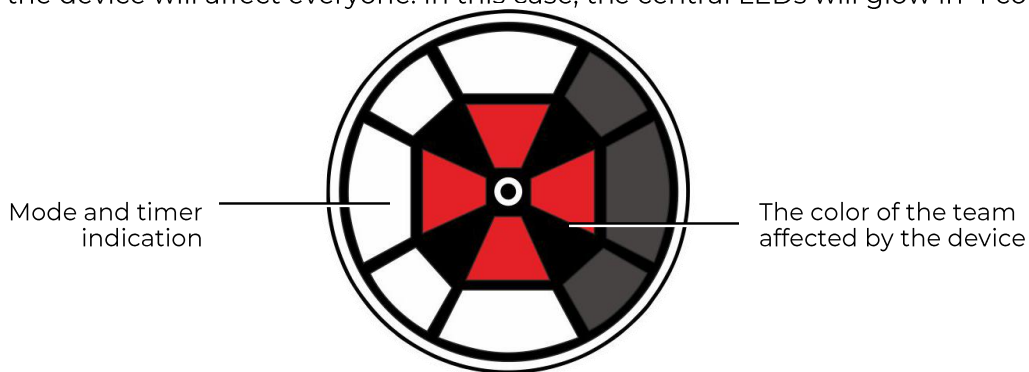

An example of a SIRIUS station light indication: editing mode - Base (white color), activation - every 5 seconds (5 LEDs on) the device will respawn the red team players (red light on central LEDs), and players of other teams will be hit by radiation (mode property)

After selecting a mode and setting it, the SIRIUS station is launched into the game using the Start Game button on the remote control .

4.2. Game Modes

4.2.1. Base mode



The Base mode is fundamentally different from the other modes. When triggered, the device gives out two game commands at once:

1. Respawn - respawns the players of the team, whose base, the starting type and fire mode of the weapon, the initial ammunition and the number of health units (only deactivated). For players who still have health units, but the last magazine is already involved, this protocol command fills the magazine completely with cartridges.
2. Radiation - decreases health units of players of other teams.

The mode is selected by the Stormtrooper preset button  on the remote control. In this case, the outer ring glows white, and the number of lit LEDs corresponds to seconds of a pause between activations. The color of the glow of the central LEDs indicates whose base will be in this round. The choice of the team is made using the buttons Assigning the color of the team on the remote control



After the game start, the central four LEDs are constantly lit with the color of the base team.

The outer circle of LEDs serves as a timer - a corresponding to the set time, the LEDs alternately light up in white counterclockwise. After the 8th LED lights up, the panel flashes purple and both protocol commands ("Respawn" and "Radiation") are distributed. Next, the cycle repeats.



The opponent's base can be deactivated. For this, it is necessary to shoot at it the number of times specified in the scenario settings (by default, when playing without a server, this number is 10). Hits are indicated by the frequent flashing of all LEDs with the color of the team of the player who shot it. After deactivation, the central LEDs start blinking, while the external ones display a countdown timer for respawn.

The Base mode is one of the most popular in scenario laser tag games. Based upon the name, the device in this mode is installed on the team bases in scenarios with a limited number of health units and ammunition. Moreover, it protects itself from deactivation by players-opponents.

4.2.2. Respawn mode



In this mode, during its activity, the SIRIUS station restores the starting number of the health ammunition points of deactivated players.

The Respawn mode is activated by the Zombie Preset button  on the remote. When setting, the color of the outer ring is red. You can also select the team that the device will affect. But, unlike the Base mode, you can still select "Affect all". To do this, you need to press the current color button once or double-click any other button to select a team color. As a result, the central LEDs light up in 4 colors.



The light indication of the station after start is almost the same as in the Base mode. The only difference is that the central LEDs are not constantly lit, but blink either in the color of the team that the device is affecting, or in four colors, if you select to respawn everyone. The outer circle of LEDs also serves as a timer. After the 8th LED lights up, the device works and respawns the players. Readiness is indicated by the frequent flashing of all LEDs in purple. Then the timer starts again and the cycle repeats. As in the Base mode, the protocol command Respawn restores the starting values of the type and mode of fire of the weapon, the amount of ammunition and health units (only deactivated players). For players who still have health units, but the last magazine is already involved, the station replenishes it.



In this mode, it is possible to force the device activation - to cover the device body with the hand, and it will activate the touch sensor.

The device can be deactivated by firing at it the number of times that can be configured in the program. Team players, who the device in this scenario is not affected on, can do it. If it is set to "Affect all", then players of all teams can deactivate. The station responds to a hit in the IR-receiver by the frequent flashing of all LEDs in blue. During the self-healing period, the central indicators flash periodically, while the external ones display a countdown timer.

The mode is used in scenarios with a limited number of health units and disabled auto-respawn. One of the options is that Sirius is installed on the bases of teams, after being configured to affect a specific team.

4.2.3. First Aid Kit Mode



In the First Aid Kit mode, the device periodically replenishes players health points. Another function is to stop "bleeding" in kits that have this parameter enabled by software.

To select and configure the mode, you need to press the Medic Preset button  on the remote control, the green light of the external LEDs corresponds to it. You can also select a team that is affected by the device, or select the "Affect all" parameter (press the current color button once or double-click any other color selection button).



After the start, the central and closest 4 LEDs of the outer circle form an image of the cross of the color of the team that the device is affecting (or a 4-color cross when choosing the effect on everyone).

The outer circle of LEDs serves as a timer - LEDs light up one by one counterclockwise. After the 8th one is lit up, the device is triggered and it replenishes the players with a certain number of health points (when playing using the remote control, the player gets one point). In this case, all LEDs flash in violet. Then the timer starts again and the cycle repeats.

In the First-aid kit mode, when the station's body is covered with the hand, the touch sensor is activated and extra points of health are dispensed.

As in previous modes, in the First Aid Kit it is possible to temporarily stop the distribution. After the device is shot a certain number of times by players on whom it does not have effect (with the parameter "Affect all" - by all players).

The mode can be used to replenish the health units of "wounded" players (but no more than the value at the start of the game), and you can configure it to "heal" only one team or all teams.





4.2.4. Radiation



The station in the Radiation mode affects the players the opposite, in relation to the "First-aid kit", action - the health points are taken away.



To select and adjust the mode, use the Vampire Preset button  (yellow color of the outer ring). You can select the teams that will be affected by the device, as well as the frequency of activity (buttons  and ).

After starting the station in the game, the internal and external LEDs blink in yellow, as if depicting the rotation of the sector counterclockwise. The activation is accompanied by frequent flashing of all LEDs in purple.



The SIRIUS station in the Radiation mode can also be deactivated, but only by the team that the station is affecting on, or by everyone if "Affect all" is set.

The device in this mode can be used as an anomaly that will protect, for example, an artifact or approaches to the base, if you choose a selective effect on a specific team.

4.2.5. Arsenal



In the Arsenal mode, the device gives the player the number of cartridges or clips set in the program (but not more than the starting value). If the game is controlled by the remote, then by default activation fills the current magazine with cartridges.

The mode is selected by the Hostage preset button . When setting up, the outer ring glows blue with the number of LEDs that corresponds to the frequency of activity. In this mode, there is no choice of teams, it means that ammunition is distributed to everyone. Therefore, when setting up, the central LEDs glow in 4 colors.



During the game round, the indication is as follows: three LEDs of the outer circle and a central one form a blue sector that rotates counterclockwise. Activation is accompanied by frequent flashing of all LEDs in purple.

In the Arsenal mode, the touch sensor is active. When the device is briefly covered with the palm of the hand, extra distribution of ammunition occurs.

A player from any team can deactivate the device.

Using the Arsenal mode is convenient in scenarios with limited ammunition - the device can be installed on bases (for example, by setting the maximum number of "lives" for kits, but only one clip) or in separate zones for replenishing ammunition.



4.2.6. Bonus mode



The mode differs from others because there is no automatic distribution of protocol commands. The impact on the player occurs only after a shot at the device. After that, all kits within the radius of SIRIUS infrared emitters double health points (up to 999 units).



The mode is activated by successive pressing of the button of the preset Sniper  and then on the button Double health units . The outer ring should glow purple. Because this mode does not have automatic command distribution; the timer is not set. Also, the color of the team is not selected; the device affects everyone (the central LEDs are lit in four colors).

During the game, the outer circle of LEDs is iridescent and shimmers clockwise, and the center ones do not glow. Distribution is accompanied by frequent flashing of all LEDs with the color of the team of the shooting player.





When playing without a server, the supply of bonuses is limited to 10 distributions, regardless of the teams that used this mode. After that, the device is on a pause for 10 seconds and then becomes active again. During inactivity, only the central LEDs radiate all the colors of the rainbow.

4.2.7. Flag



The mode is turned on by successive pressing of the buttons Hostage preset  and Change the power of the IR-beam . It allows you to play games according to scenarios of the CTF format - Capture the Flag.

The basic principle of these scenarios is that the opponents' SIRIUS station generates electronic flags, they must be "captured" and delivered to their base.

When the mode is selected using the Remote Control, the internal LEDs light up in the team color (you can change the team color assignment buttons), and the number of the outer ring LEDs glowing in blue will correspond to the number of flags that must be captured and delivered to your base (maximum 8 flags). The number is set by pressing the buttons Remove player  (more) Replenish ammunition  (less).



After the start of the game, the central LEDs glow with the team color and the white LED "rotates" around the outer circle clockwise. When launched from the remote control, the default game device sends out a protocol command "Respawn" to the players of its team every 60 seconds via the IR-channel (this parameter is configurable in the program).

To "capture" the opponent's flag, it is necessary to shoot from a laser tag gun at the SIRIUS of the other team from close range. It is necessary to shoot at the device before the sound message from the laser tag gun speaker: "The flag is captured", and the LEDs of opponent's headband will not start flashing alternately in purple and the color of the player's team. After the flag is captured by the opponent, SIRIUS becomes inactive, but after a certain time in the program (when playing with the Remote Control, after 15 seconds) generates a new flag. However, during this period, the base is available for accepting the opponent's flag.



To surrender the flag, you must shoot at your team's SIRIUS also before receiving the Flag accepted confirmation. After that, the device indication will change - the white LED will continue to "move" in a circle, but one LED will be added on the outer circle, which will be on constantly. When the next flag is delivered, two LEDs will already be on, etc. up to 8 flags.



"Capture the Flag" scenarios have many options, but when controlling the game with the Remote Control, only one condition for ending the game is available: "Deliver the required number of flags". Therefore, the victory in the round is won by the team that will be the first to deliver the given number of opponent's flags to their base.

4.2.8. Random mode



When the SIRIUS station is activated in the Random mode, one of three protocol commands is distributed in random order: Double the lives, Arsenal or Radiation.



To enable the mode, you must first press the Doctor preset button  (green LEDs), and then the Change IR beam power button . The outer ring should light up in orange. The frequency of distribution is set by setting the timer. There is no choice of teams. Everyone is affected after the timer countdown.

After the start, the LEDs in the outer circle randomly flash in different colors, and the central 4 LEDs act as a timer. According to the time set they light up in white counterclockwise.



Affecting players, all LEDs frequently blink purple.

The SIRIUS station in the Random mode can be used in scenarios with anomalous zones - an element of unpredictability will add interest to the game.



4.3. System mode

In cases when the club has several playgrounds, and laser tag equipment is used on each one using a Wi-Fi network and computer programs, it is necessary that the devices on each of the arenas are connected to their specific access point. This is one of the conditions for stable operation of the equipment, correct transmission and processing of statistics.

For the SIRIUS station, the access point is selected using the remote control. To do this, go to the system mode:

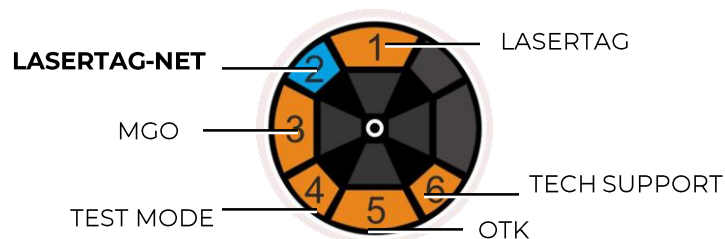
1. Point the remote control IR emitter at the Station receiver and press the Sniper preset button  - 6 LEDs of the outer ring should light up, and five of them - in yellow, and one - in blue. A flashing LED indicates which access point the device is connected to. The countdown starts from the top indicator counterclockwise.
2. The upper LED can be identified by the mounting loop on the back of the device (it is on top).



If necessary, change the access point, use the Delete the player  (forward) and Refill ammunition  (back) buttons.

To confirm the change of access point, press the Start Game button on the remote control and the device will switch to the game mode.

When switching on, the device immediately goes into the mode to which it was configured before the last shutdown. At the same time, it starts searching for an access

point. When connected to the server, the LEDs begin to glow in different colors. The station is ready to set up or start the game.

The procedure for, configuring, and controlling the SIRIUS Station using computer programs are described in part 3 of this manual.

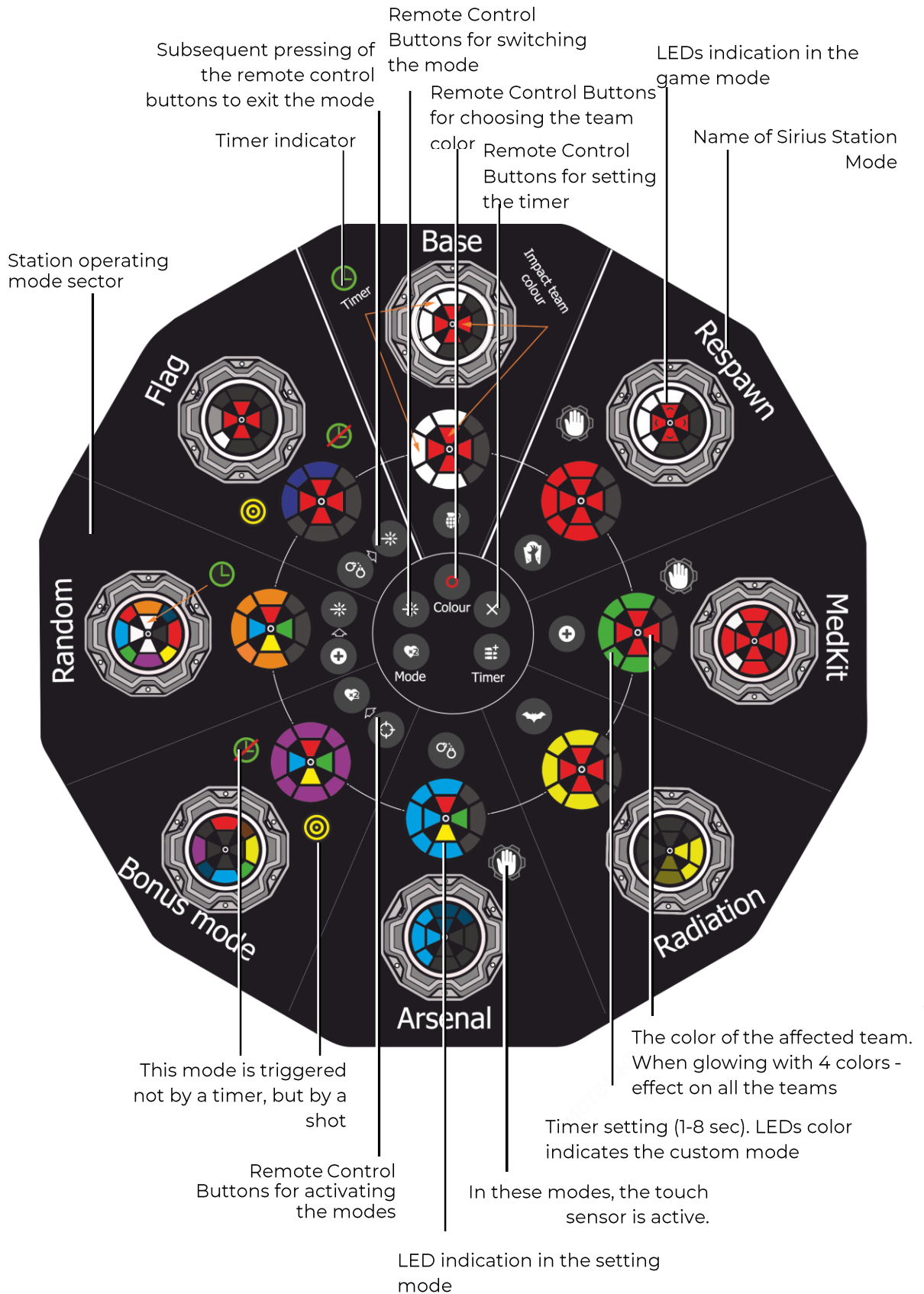

SIRIUS Station Graphic Handbook



5. Multistation

The Multistation (MS) is a multifunctional additional device for playing laser tag which significantly increase the list of possible scenarios.

The main advantage of this device is the availability of the LED screen (panel 192x192 mm, 1024 pixels), which clearly shows the mode the station is being used in. Also, thanks to a futuristic design, interactive animation and side lighting, Multistation makes the games more colourful and spectacular and becomes an adornment of any platform.

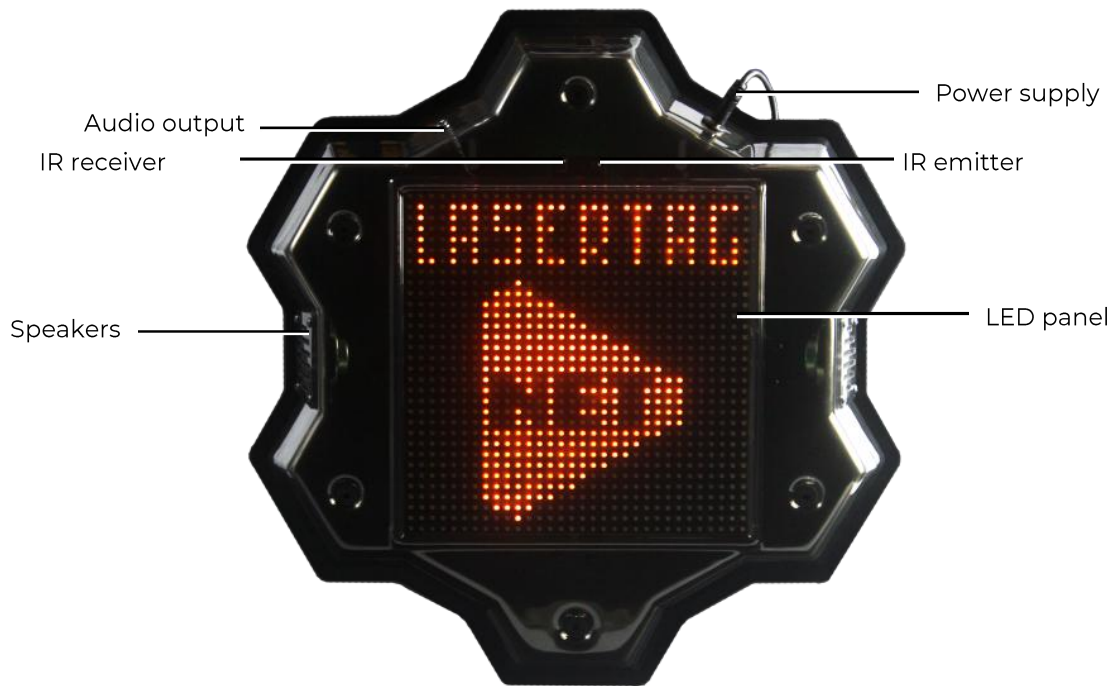

External Elements of the Multistation

Power supply: 220 V network via 8.4 V 2 A.

Sound: built-in speakers + audio output.

Initially, the MS was developed to use it on stationary arena sites. But the device is quite suitable for outdoor laser tag. The only limitation is the lack of autonomous power. Therefore, the multi-station must be located in close proximity to the power outlet or use an external battery (powerbank). Multistation must be positioned on the playground in a shaded area so as to avoid direct sunlight and strong directional light on the device's screen.

Full configuration and control of the device are carried out through computer program (Lasertag Operator for Android). However, it is possible to turn on the modes using the remote control.

In the current release, the Multistation can work in seven modes: First-aid kit, Arsenal, Respawn, Bomb, Check Point, Radiation and Base.

When you turn on the device, the screen initially shows the company's logo. Next, the device is searching for a server and, if the connection is successful, the multi-station switches to the game mode that is set in the script of the computer program.

When playing without using a server, all modes except the Domination box mode can be turned on using the remote control buttons. This mode will use the default settings.

5.1. Game modes

5.1.1. First-aid kit mode



In the First-aid kit mode, health units are distributed over the IR-channel with the interval set in the settings. In addition, at the moment of activity, the device stops "bleeding" from the kits.

To enable the mode using the remote control, it is necessary to direct the emitter of the remote control at the receiver of the Multistation and press the Medic preset button . In this case, the default settings are used: every 10 seconds the device will give out 10 health points to players of all teams in the impact zone of infrared emitters.

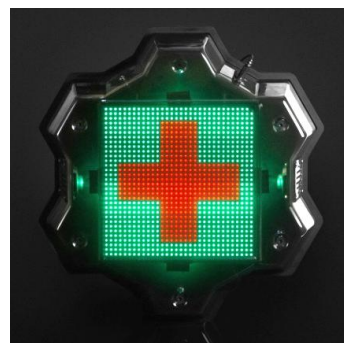

Using the computer programs you can configure such settings as the frequency of activity, the number of health points distributed, the color of teams the device affects, the number of shots for deactivation, etc.

The mode is used in "survival" scenarios with a limited number of health points.

5.1.2. Radiation mode



Unlike the First-aid kit mode, in the Radiation mode, health points are taken away at set intervals.

The default setting via the remote control is switched on by pressing the Vampire Preset button : every 10 seconds the affected players lose 10 health points.

The advanced settings of the Multistation in the Radiation mode are available in computer programs.

The best use of MS in this mode is in scenarios with artifacts, and protection of the approaches to the base of the team.

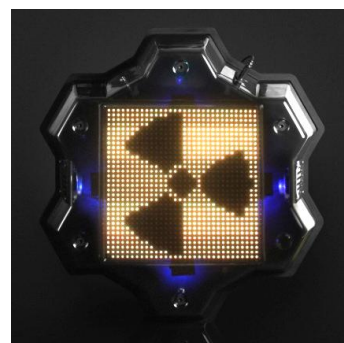

5.1.3. Respawn mode



In the Respawn mode, the Multistation restores the number of health units and the ammunition of the kit to the starting state.

It is valid only if the player at this moment has no health units left. The only exception is that the device fills the last magazine for a "live" player.

From the remote control, the mode is launched by pressing the Zombie preset button . The frequency of operation is 10 seconds.

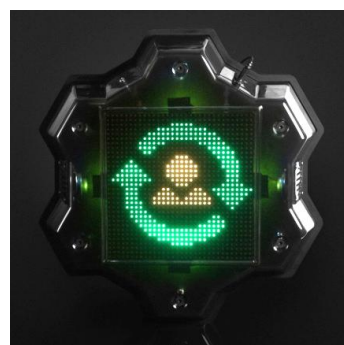

In computer program, you can select the interval of activity, the players of which teams will respawn the device, the number of shots to deactivate the device, and the inactivity time after deactivation.

The mode is used in many scenarios with a limited supply of health units and ammunition.

5.1.4. Arsenal mode



In this mode, cartridges or clips can be replenished in one of the ways (selected in the program) - either by waiting for the automatic distribution or by firing from the blaster at the device. At the same time, in the clips shown on the screen, the upper cartridge is sent to the chamber, and two lower ones rise in its place. After using the third cartridge, the "conveyor" loads the next package of ammunition.

To enable this mode with the remote control, you must press the Hostage preset button . By default, every 10 seconds or after a shot at the device a clip will be filled automatically.

Computer program allow you to configure whether cartridges or clips are added to the kit and in what quantity. You can also configure the number of shots to deactivate the device and the time of inactivity after deactivation. Any team regardless of color can use the mode.

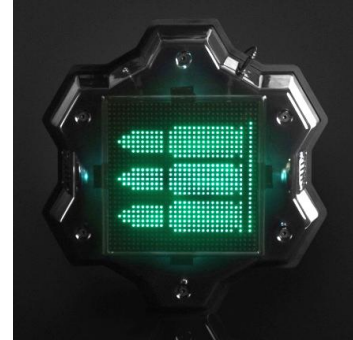

The mode is used in "survival" scenarios with limited ammunition.

5.1.5. Bomb mode



The Bomb mode allows you to conduct scenarios that resemble one of the episodes of the computer game "Counter-Strike", namely, "Bomb Defusal". Starting with the multistation firmware version MS_v2.1.14, the mode functions in a new format.

Initially, players are divided into two teams - miners, who set the bomb and sappers, who must disarm it.

Simplified scenario of a game using Multistation in the Bomb mode is as follows:

- A team of miners sets a bomb with shots the number of which is set in the program. The team of sappers at this time is trying to prevent this, hitting the players of the miners team. The dynamics of the installation can be observed on a progressive scale at the bottom of the screen of the Multistation. Moreover, the device does not respond to sapper shots.
- If during the game round the installation did not complete, or the bomb did not explode, the victory is awarded to the team of sappers.



- If a bomb was installed, the speaker of the Multistation reports: "Bomb has been planted" and the timer starts, which is graphically displayed on the screen as a burning wick of an old grenade. The "wick" is lit in proportion to the time set in the Clock work field. Now tasks of the teams become diametrically opposed - the team of sappers needs to disarm the bomb during the timer work, hitting the device

(shots are also controlled by the lower two rows of screen LEDs), and the miners must counteract this by hitting the opponent. Accordingly, the station now does not respond to shots from miners.

- The following are two options. The sappers manage to disarm the bomb, and it returns to its original state - the message “Bomb has been defused” sounds and the ring with a crosshair appears on the screen again. Or the bomb explodes.

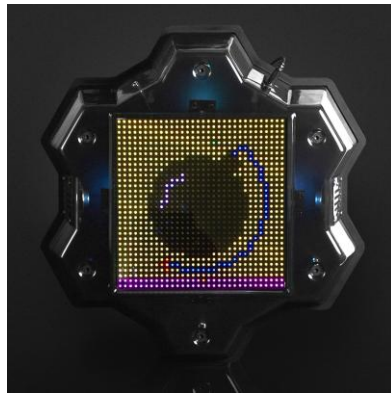

You can read more about using the Bomb mode in the “Instructions for using the Bomb MultiStation mode”, which can be downloaded here: <https://lasertag.net/manuals/>



When starting the mode with the remote control (the Sniper preset button ), the scenario goes as follows: in order to set a bomb, the red team must shoot the MS 10 times. Then the timer-wick is turned on and the blue team is given 10 seconds to deactivate the bomb with 10 shots. Since in this scenario, deminers have very little time, it is recommended to equip the team of miners with fewer players.

5.1.6. Base mode



One of the most popular modes. The main difference is the double protocol command. It is also possible to destroy (deactivate) the opponent’s base.

After the scenario starts, an image of a waving flag of the team color appears on the screen of the Multistation. The LEDs of the side illumination also glow in the same color. At the time intervals set in the program, the device distributes the Respawn command via the IR channel, which restores the initial values of the health units and ammunition of the players of its team (for players who still have health units, but the last magazine is already involved, the station replenishes it). With the same frequency, the Base distributes the Radiation command, which acts on players-opponents. With these activities, a corresponding picture appears briefly.

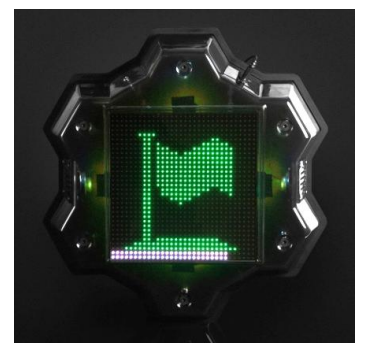
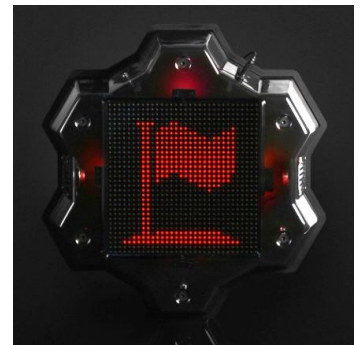

To destroy the opponents' base, you need to shoot at the device set in the scenario settings the number of times. In this case, the white bar at the bottom of the screen will graphically display the degree of destruction. After the strip reaches the right



edge, an explosion animation is displayed on the screen and the crossed-out flag appears. From this moment, the Base is inactive.

If the option "The game ends head of schedule early if the Base is destroyed" is enabled in the scenario, the game ends ahead of schedule with the victory of the team that destroyed the opponent's base.

If this parameter is turned off, then after the time set in the "Inactivity period" setting the database will self-recover.

To start the mode with the remote control, press the Stormtrooper preset button . Then you need to select the color of the team whose base it will be by using the Assign team color buttons .

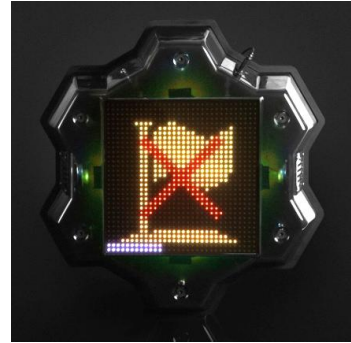

The default scenario requires that the protocol commands are issued one by one - first, "Respawn", after 5 seconds, "Radiation", then after 5 seconds again, "Respawn", etc. To deactivate the base, rival players need to shoot the Multistation 10 times. After a 2 second pause, the base will respawn.

The Base mode can be used in any scenario with a limited number of health units and ammunition.

5.1.7. Domination Box



The Multistation algorithm in the Domination box mode is functionally different from the algorithm of the traditional Domination box. The fundamental difference is in recording captures and scoring. Because of this the autonomous operation of the device without a server or activating the mode via the remote control is not provided.

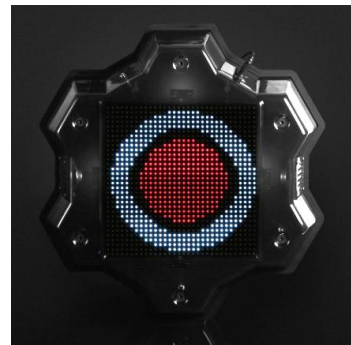

When the round starts, a white target-ring appears on the screen. When a blaster beam hits the device, a color circle of the player's team appears in the center of the screen. On subsequent hits by players of the same team, the circle will increase. The circle growth dynamics corresponds to the value "Number of shots for activation/deactivation" set in the program, i.e. if 5 units are set, the circle will fill after 5 shots, if 20 - after 20.

If a player of another team hits the device, a circle of color of the second team appears in the center (the circle of the first team does not reset) and with subsequent shots the circle of the new team begins to increase in size.



The task of the players is to fill the entire circle with the color of their team first, after which the point is considered captured and only after that points will be awarded to the capturing team (1 point in 1 second of retention).

After the capture, the task of the players of other teams is to intercept the point. By firing shots at the device, they fill the circle with their color, and players of the captured team reduce it with shots. If the other team nevertheless intercepts the point, then points accrue to it already.

In order to prevent crowds of players near the Multi-Station when it operates in the Control Point mode, the program can be set to have a Radiation effect on all players (the distribution period and the damage are also set in the program).

This mode can be used in scenarios with the option “The game ends ahead of schedule if one of the teams scores the set number of points”. At the same time, the game ends ahead of schedule with the victory of the team that scored the set number of points, and the image of the color cup of the winning team is displayed on the screen.



If the parameter of early termination is not turned on and the game ends in time, the team that scored the most points by this time wins. If two or more teams have equal number of points, the victory is awarded to the team that owns the point by the time the game timer stops.

5.2. System mode



The system mode allows you to find out the firmware version of the Multistation Microcontroller, and select an access point. This is necessary if the club simultaneously hosts games on several sites and access points with different names are used to communicate with the server.

The setting is performed as follows:

1. Turn off all the routers involved in the gaming network.
2. Switch on the Multistation. If before, this the device was in the game mode, turn it off and on again.
3. Aim the IR emitter of the remote control at the Multistation and press the Assign the team color red button .
4. The shortened names of the access points and the firmware version (in yellow digits) will appear on the screen. The blue triangle with its location and angle shows the current name of the access point to which the device is configured:



LT – LASERTAG, OTK - OTK ,
 LTN - LASERTAG-NET, TSP - TechSupport;
 MGO - MGO, TSM - Test mode.

5. If necessary, change the access point, use the buttons Delete the player  (forward) and Refill ammunition  (back).
6. To confirm the changes, click the Start Game button .

Setting of modes and control of additional devices (DBs, SIRIUS, Multistation) from the computer program Lasertag Operator is described in part 3 of this manual.



6. Supernova laser tag bomb

The SUPERNOVA laser tag bomb is an additional device that makes it possible to implement in laser tag scenarios with the installation and clearance of "time bomb", including the scenario "Bomb planting" from the computer game Counter Strike.

The device consists of two parts:

- portable bomb;
- stationary NFC platform (at least 1 pcs).

The bomb is activated/deactivated only when it is on the platform. The number of platforms can be more than the number of bombs, and they can be placed in different places on the site.



Components of the Laser Tag Bomb

A portable bomb is a device with a plastic body framed by expanded thermoplastic elastomer. The bomb has an autonomous power supply from built-in batteries, a speaker, a charger connector, an action button, an electronic timer and a carrying handle. The electronic circuit board is equipped with a Wi-Fi module for communication with the server and NFC-module to contact with the platform.

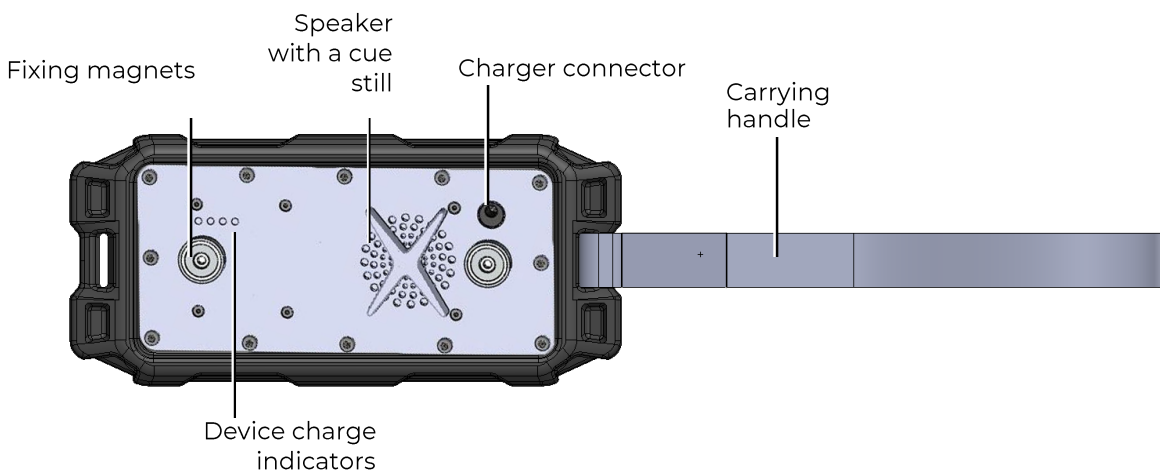

Portable bomb. Back view



The stationary platform is equipped with special mounting holes for installation on vertical or horizontal surfaces of the site. A recess in the body of the platform and built-in magnets allow the bomb to be securely fixed in case of installation. An NFC card (mark) is also embedded in the platform, which identifies the place where the bomb was planted.















The buttons on the Remote Control for controlling the laser tag bomb

The bomb is turned on by pressing the action button for 3 seconds. After turning on, the device goes into the "Out of game" mode and the digital display shows a smoothly blinking indication in the form of horizontal segments with a colon in the middle: «--:--».



In this mode, you can change the volume of the device speaker from the Remote Control by directing the Remote Control emitter towards the front panel of the laser tag bomb. The "Medic Preset"  button increases the volume, the "Hostage Preset"  button decreases the volume.

It is possible to quickly change the access point in the out-of-game mode - using the buttons on the Remote Control. To do this, you need to hold down the control button, direct the Remote Control emitter to the front panel of the bomb and press one of its buttons:

Remote Control Button	Name	Access point name	Display on the bomb display
	Medic preset	LASERTAG	
	Hostage preset	Test mode	
	Sniper preset	OTK	
	Stormtrooper preset	TechSupport	
	Vampire preset	LASERTAG-NET	
	Zombie preset	MGO	

Also, in out-of-game modes, it is possible to see the charge of the built-in batteries - pressing the action button for 1 second activates four white LEDs located on the back part of the device body. The glow of 4 diodes corresponds to a charge of more than 75%. When the charge is 50 to 74%, three LEDs light up. 25 to 49% - two LEDs. Blinking of one indicator means a critical value - less than 24%.

Turning off in the "Out of game", "Bomb deactivated", "Bomb detonated", "Service" modes is performed by pressing the action button for 2-3 seconds until the "OFF" message appears on the screen.



In game mode, to turn off the power, press and hold the button for 90 seconds. In this case, if you release the button during this time, the progress is reset, and to turn off you need to press the button again for 90 seconds. Also, to quickly turn off the device, you can use the function button with one dot  on the Remote Control, aiming its emitter at the front panel of the device. This method works in all modes.

6.1. Using the Bomb in laser tag games

Before the game stationary NFC platforms are installed in different places of the playground, and the players are divided into two teams:

- miners (or terrorists like in the game Counter Strike), by default, it is the team of red;
- sappers (special forces), by default, it is blue team.

The instructor directs the emitter of the Remote Control to the front panel of the portable bomb and presses the "Start game"  button. The bomb switches to the "In game" mode, which is indicated on the bomb timer dial by the stripes moving clockwise.



The bomb is handed to one of the players on miners team and the round starts.

The task of miners is to plant a bomb on one of the platforms.

The task of sappers is to prevent the planting, and to deactivate the bomb before the explosion if it is planted.

6.2. Bomb planting

The bomb is planted as follows:

1. After the player with the bomb and who still has health units, manages to approach the planting point - one of the stationary platforms (to the plant - as it is called in CS), the player must insert a portable bomb into its socket (the button should be on the right).
2. The device switches to the "Bomb installed" mode - the numbers on the display start blinking, showing the time at which the timer is set. The clockwork is configured in the appropriate section of the Lasertag Operator program (Scenario Settings/Additional Devices/Bomb Settings). By default, it is 1 minute. In this case, the bomb reader receives data from the NFC card embedded in the platform, and information about its number is transmitted to the server. If in this mode the bomb is removed from the platform, it switches to the previous mode "In the game" and the corresponding indication turns on.

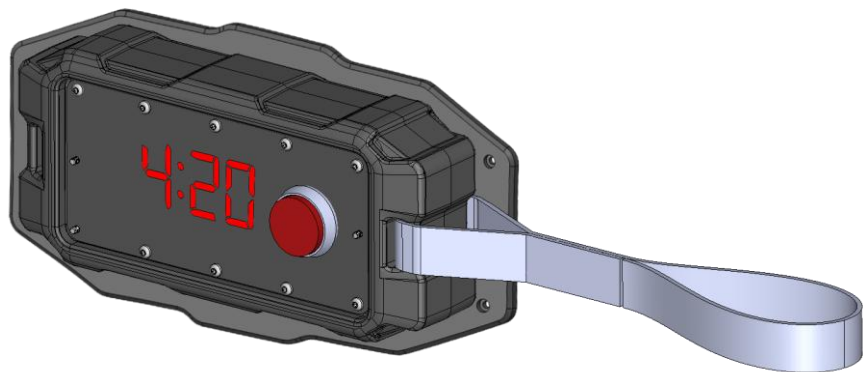

3. After a few seconds, which are accompanied by a sound signal, a hint will appear on the bomb screen - the inscription "Shot". It says that the player from the miners team must confirm that his individual kit is active - it is necessary to shoot from his laser tag gun at the bomb receiver located behind the front panel of the body.



4. The successful confirmation is indicated with a green LED in the upper right corner of the screen and then the next hint appears on the screen - the inscription "Hold". If a player of the sapper team shoots at the device, the LED turns red, and the device doesn't switch to the next mode.



- Next, you need to press and hold the action button for 3 seconds. The bomb activation process is indicated by the absence of flashing of the timer display and the sound from the device speaker. If a player of miners team did not hold the button for 3 seconds, or at that moment a player of sappers team fired at the bomb, the activation process will be canceled. The miner should shoot the bomb again and repeat the pressing of the action button.
- As soon as the bomb switches to the "Bomb is activated" mode, the countdown timer starts - the display shows the time decreasing every second until the explosion. At the same time, a short beep will be played by the bomb speaker every second. During the last 10 seconds before the explosion, the frequency of signal playback increases up to several times per second.



- If during the operation of the clockwork the bomb is not deactivated, an "explosion" occurs - the inscription "Booo" blinks on the display, LED flashes with overflow of colors, a corresponding sound is played and all kits within a radius of about 10 m are hit via the Wi-Fi channel. The amount of damage is selected in the Lasertag Operator program (Scenario Settings/Additional Devices/Bomb Settings). The default is 100 health points.



- The instructor can forcibly stop the clockwork with the help of the Remote Control - it is necessary to direct its emitter to the front panel of the bomb and press the "Remove player" button . The device switches to the "Out of game" mode. To reuse the bomb after that, it must be removed from the platform and re-started with the remote control.

6.3. Bomb clearance

If sappers team failed to prevent the installation and activation of the bomb, it must be deactivated. Such procedure can be done while the timer is running, but not later than the time set in the "Clearance time" parameter of the bomb settings in the program (10 seconds by default).

To deactivate the bomb:

- The player of the sapper team, who approached the planted bomb, also needs to confirm the activity of his kit - shoot from their laser tag gun into the front panel of the device. The device displays the "Hold" hint, but the device timer continues to count down.
- The player is given 3 seconds to press and hold the action button for a set clearance time (10 sec by default). If the sapper does not have time to hold down the button in 3 seconds, the screen displays the inscription "Shot" again and for the next attempt it is necessary to repeat the shot from the laser tag gun. The device reacts to the shots of miners with a red LED glow and does not switch to the next mode.

3. If the clearance process is started when the timer has less time than is necessary for clearance (10 sec by default), the explosion still occurs, i.e. it is impossible to deactivate the device during this time.
4. In the operating mode of the clockwork, there is a "protection against violations of the game rules": if at this time the bomb is removed from the platform, the sound "Alarm" is played and the device switches to the "Out of game" mode. The inscription "Error" (error) is displayed and the instructor must restart it from the Remote Control to continue the game.



5. Successful deactivation of the bomb is accompanied by a timer stop and a special sound signal, the screen displays the inscription "SAFE", the LED glows blue.



6. To reuse the bomb, it must be removed from the platform and activated using the Remote Control.

6.4. Algorithm for using a laser tag bomb controlled with the Remote Control and with default settings

The red team (miners) plant a bomb.

The blues (sappers) prevent miners, and if a bomb is planted, they detonate it.

The time for pressing the button after the confirmation shot is 3 s.

Explosion timer time - 1 min.

Demining time is 10 seconds.

Damage when hit by Wi-Fi - 100 health units.



The bomb is turned on by holding down the button for 3 s

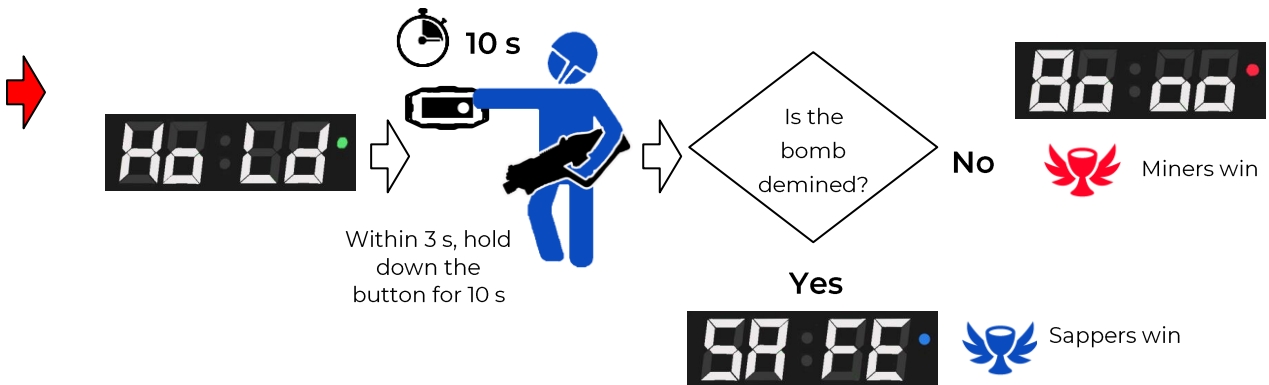
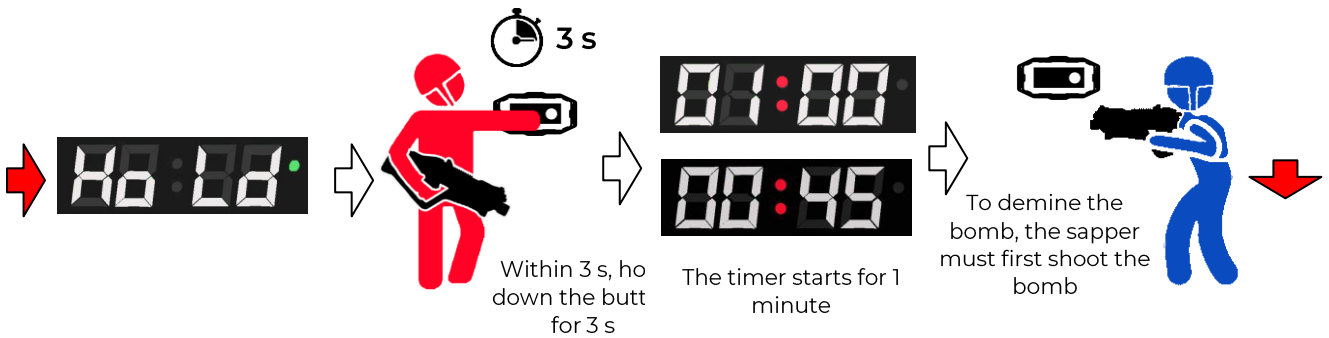
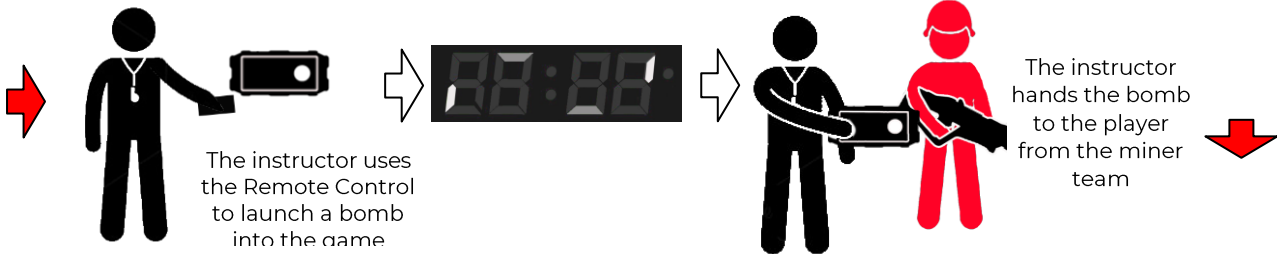

You can choose various scenarios playing with the Bomb device. For example, it can be configured so that each team has its own portable bomb in a round. In this case, a team of miners and sappers is selected for each device, and then the color of the bomb tile decoration in the program will correspond to the color of miners team.

You can create such a scenario when not two, but three or four teams participate in the game. Each team has its own bomb color coded (for example, using colored tape). In the settings of each mine, a different color for the miners team is selected, and in the settings for the color of sappers team, "All" is selected. Then a player of any team can execute bomb clearance, and so that he does not accidentally begin to deactivate the bomb of his team, the player must pay attention to the marking color.

In long-lasting laser tag games, more explosions and clearances than there are bombs can be set to fulfill the game finishing condition. In this case, after the explosion or clearance by the instructor, the bomb is removed from the platform, transferred to the starting position of the miners team, and re-launched into the game. Each successful action of teams is reflected in the final statistics.

Alternatively, you can further bring the scenario closer to the computer game Counter Strike if exclude from the settings any "respawn" of players and add one more condition for the end of the game: "One team left". In this case, the game ends either with a bomb explosion, or mine deactivating, or when all the players of one team are deactivated.

6.5. Service mode

The service mode allows to change the device ID number, the Wi-Fi network to which the bomb connects automatically, and reset the device settings to default using the Remote Control.

To switch to this mode, hold down the control button on the turned off device, wait for the "--:--" indication to appear and then hold the button for another 20 seconds. The sign of the successful switching to the service mode is the indication on the board - the inscription "SEr" (service) which changes to the indication of the setting mode "CArd".

Some of the system mode settings are relevant only for the developer, including platform programming ("CArd" setting) and formatting of the built-in memory ("For" setting). To avoid disruption of the device operation, it is recommended not to enter the submenu of these settings.

You can navigate in the main menu of the service mode using the buttons on the Remote Control "Change the power of the IR-beam" (forward) and "Double health units" (back).

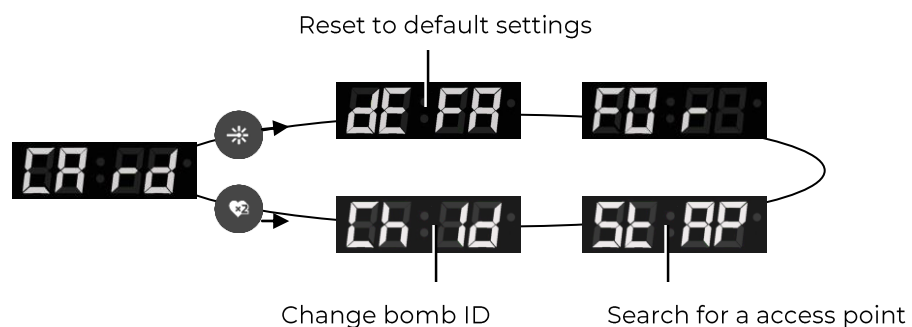

Moving in the main menu of the service mode

6.5.1. Restore device settings to default

To restore the default settings of the device, select in the menu "dEFA" (default), direct the emitter of the Remote Control to the front panel of the bomb and press the "Start game" button . The inscription "StAr" (start) will be displayed. To reset settings, press the "Start game" button on the Remote Control again. The message "dOnE" will be displayed on the screen as evidence of a successful reset.



To return to the main menu, here and further, you can use the button on the Remote Control "Delete player" .

6.5.2. Search and connect to the access point

Next mode assumes interaction with the settings of the access point. Initially, the Bomb Supernova is configured in such a way that it connects to the default access point (LASERTAG), and if it does not find one, it connects to the nearest available network from the list. However, if the games using the bomb take place on several playgrounds at the same time, they must be connected to different access points. You can make another Wi-Fi network the default access point.

In the main menu, this setting is indicated by the inscription "StAP" (start access point).



After entering the menu using the Remote Control button "Start game" , the device makes three attempts to connect to the default access point (default). If it failed to connect to it, the device selects the next point from the list, then tries to connect to the default access point again and then repeats this algorithm in a circle. If the bomb connects to a point which differs from the default access point, it continues searching for the default point without interrupting its operation until it is found.



The following indication is displayed on the screen. When trying to connect to a point from the list, a blinking inscription "AP_n" (access point_n) is displayed, where n is a specific number of the access point. If the connection is successful, the inscription stops flashing. If you connect to the default access point, the inscription looks like "AP_d" (access point _default).



The following access points correspond to the numbers on the screen:

0 – TechSupport, 1 – Testmode, 2 – TDM (point for internal developer tests), 3 – MGO, 4 – OTK, 5 – LASERTAG, 6 – LASERTAG-NET, 7, 8 – points are occupied for internal developer tests, do not use.

It is necessary to control that the bomb and the server are connected to the same access point.



To set a new access point "by default", use the buttons "Change the power of the IR-beam"  (up) and "Double health units"  (down). An inscription with the corresponding point from the list is displayed on the screen, the search algorithm "scrolls down" to the desired access point, the device tries to connect. If you press the "Start of the game"  button at the same time, then the access point with this number is set as default and ALWAYS, when searching for points, the connection priority is given to it.

The confirmation of successful assignment is the inscription "dOnE".



After successfully assigning the "default" status to the access point, it changes from "AP_n" to "AP_d". To return to the main menu, click on the "Remove player"  button.

6.5.3. Change laser tag bomb ID

Another setting of the main menu: "ChID" (change ID) - allows you to change the device ID. To enter the mode, as for other modes, you must press the button on the Remote Control "Start game" . The screen displays the device number in the "I_n" format, where n is a number from 1 to 999. By pressing the Remote Control buttons "Change the power of the IR-beam"  (up) and "Double health units"  (down) select the required number. Apply by pressing the "Start game" button again.



After successful application of the settings, turn off the device (hold down the control button for 2-3 seconds) - the screen displays the inscription "Off", and after that release the button. Then you can turn on the bomb again in a normal mode.

7. Wi-Fi router

The Totolink N300RH wi-fi router is supplied by the company with the laser tag equipment. The router is based on the Realtek RTL8196E-CG network processor and is capable of providing data transfer rates of up to 300 Mbps.

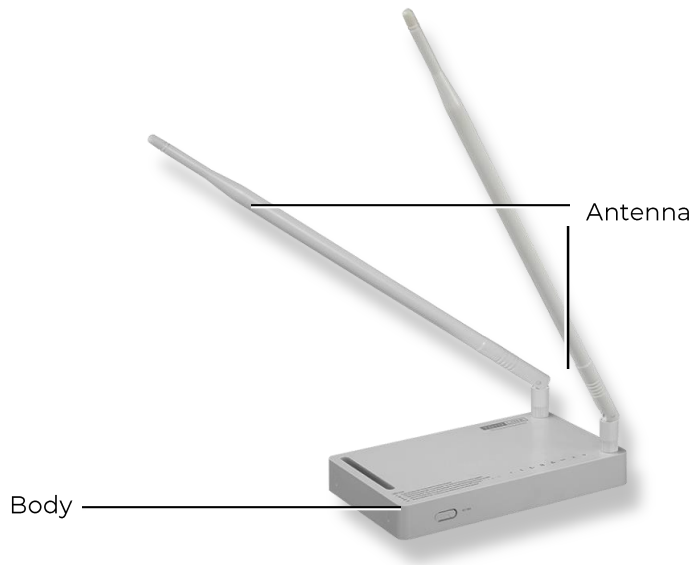

Totolink N300RH general view

The router is equipped with an external power supply (12 V, 1A), a UTP cable and two antennas with a gain of 11 dBi.

! When using a portable power source (powerbank) for operation of the router, the output voltage is necessary to be 12 V - the rated voltage of the router's power supply.

The Reset button resets all settings of the router to factory settings.

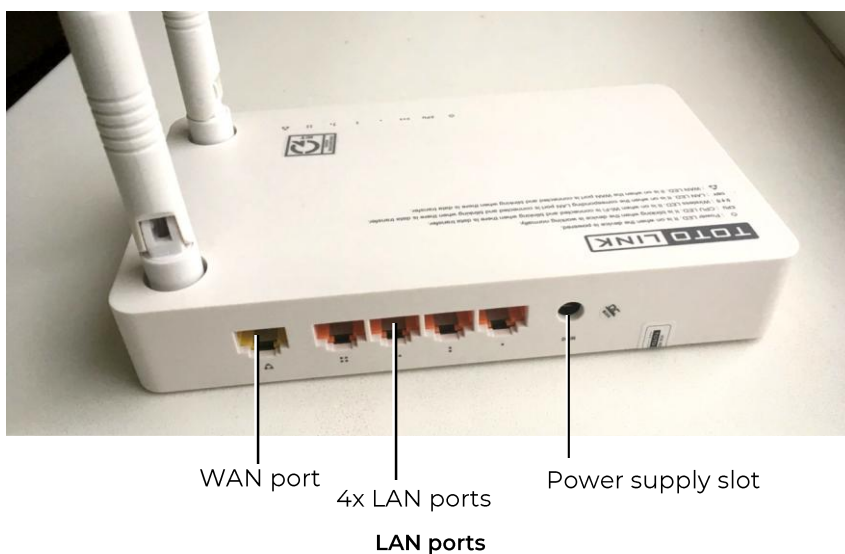

There are 4 LAN ports on the connection panel, a WAN port for connecting the provider's cable and a slot for connecting the power supply.

- ! **The device comes fully configured to work with software and laser tag equipment manufactured by the company and does not require additional changes.**

7.1. Setting the router in case of accidental reset

If the settings of the router were reset for some reason (for example, you accidentally clicked the Reset button or made changes to the settings that led to the incorrect operation of the router), you should configure it yourself (using the firmware of the N300RH V4 router as an example).

7.1.1. When using an Android tablet or smartphone

1. Place the antennas vertically and turn on the router.
2. The list of Wi-Fi connections of the device should display the network name corresponding to the brand of the router, in this case Totolink N300RH
3. In any browser installed on the tablet, enter the address 192.168.1.1 in the URL entry line.
If 192.168.1.1 does not open, you should reset the router to the default settings - on the front panel of the router, press the RST-WPS button for 15 seconds, and then release it. Repeat opening the router configurations page.
4. On the back of the router, read the password from the sticker set by the company's QC, for example:

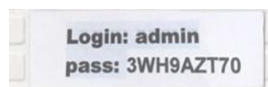

5. In the window that appears, enter User Name: admin, Password: from the sticker.
6. Select the "Advanced settings" menu item at the top of the screen.
 - In the "Wi-Fi network" menu, in the "Wi-Fi network protection" sub-item, set:
 - SSID (Wi-Fi network name) – LASERTAG¹;
 - Wi-Fi network protection algorithm - WPA2;
 - Supported encryption algorithms WPA2 - AES;
 - Wi-Fi Network Security Key - 2015LT2015;
 - Apply the selected settings with the "Apply" button.

7.1.2. When using a Windows PC

1. Check and, if necessary, set the computer to automatically obtain an IP-address.
2. Get the router configuration file totolink_config.dat from the technical support of the company and save it in any directory of the file system of your computer.
3. Through any of the 4 LAN connectors, connect the router to the network card of the computer using the UTP cable, which is included in the package.
4. Arrange the antennas vertically. Switch the router

¹ The equipment produced by the company allows up to 5 different names of Wi-Fi networks, each with its own password. Information on setting up can be obtained by contacting technical support.

5. In any browser (Opera, Google Chrome, Internet Explorer) installed on the computer, enter 192.168.1.1 in the URL input line. If 192.168.1.1 does not open, you should reset the router to the default settings - on the front panel of the router, press the RST-WPS button for 15 seconds, and then release it. Repeat opening the router settings page.
6. In the window that appears, enter User Name: admin, Password: admin.

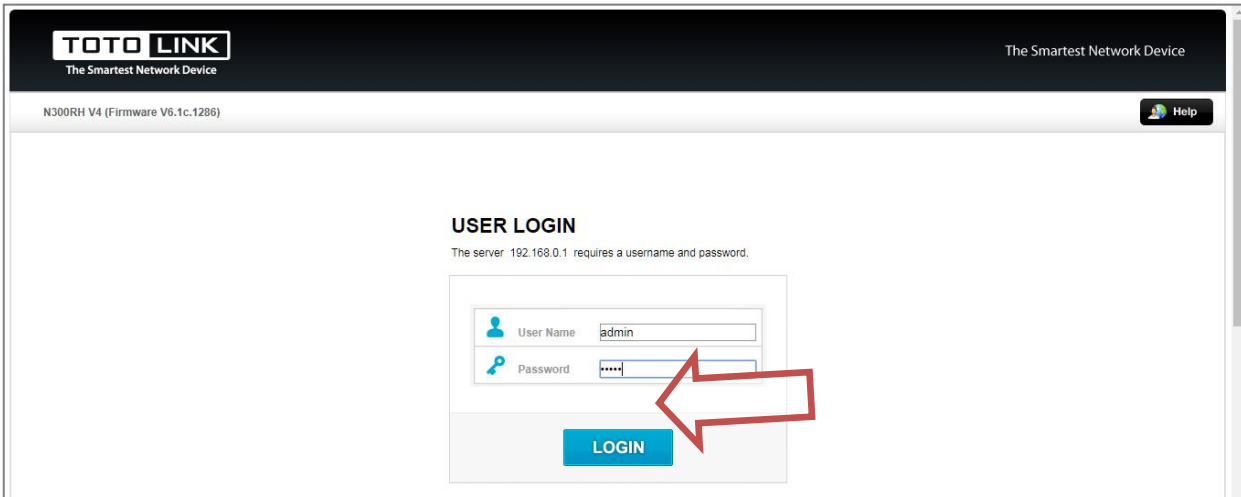

7. In the Easy Setup window, select the Advanced Setup mode.

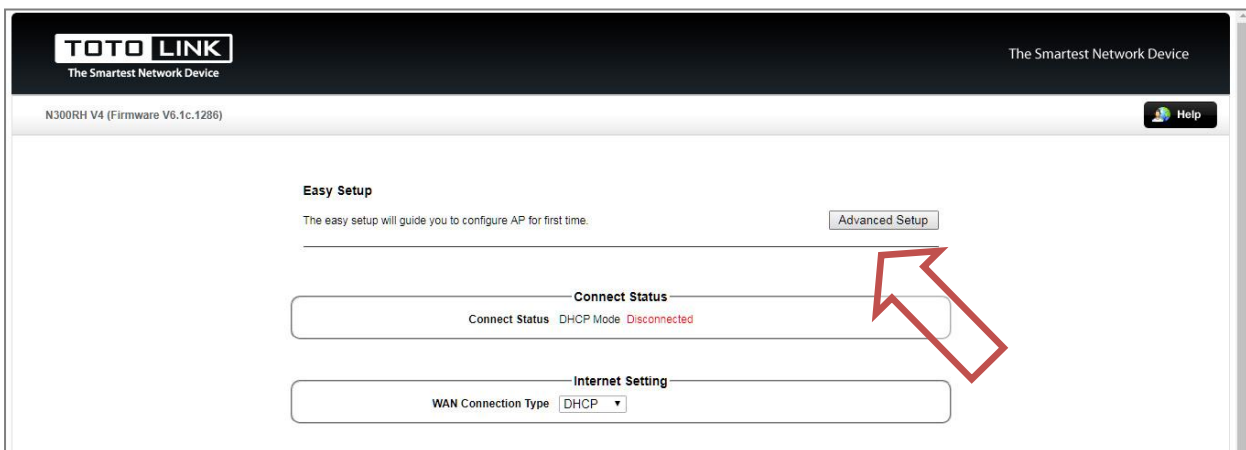

8. In the menu item Operation Mode, select the item Gateway Mode and click on the "Apply" button.

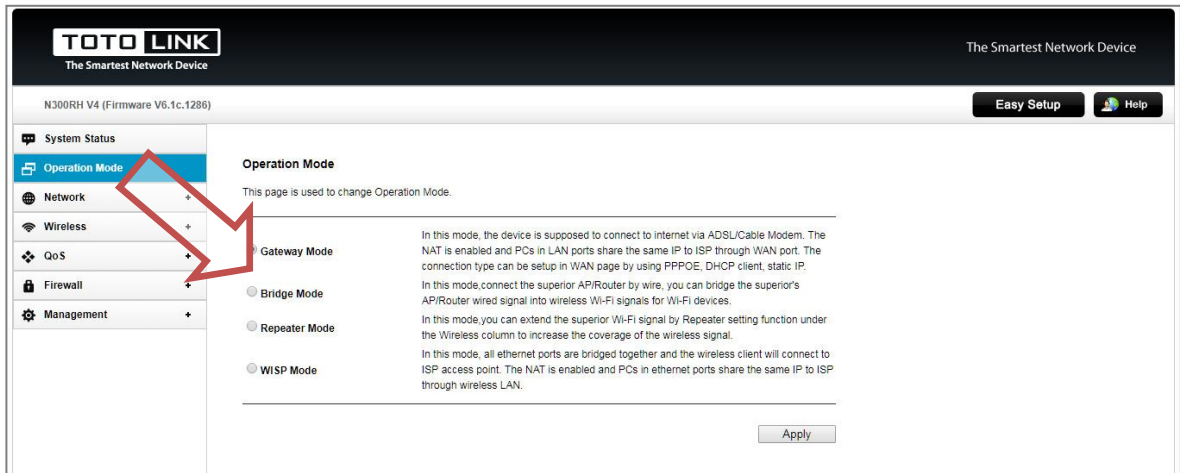

9. In the Network menu select LAN Setting and set the parameters:

- IP Address (IP-address of the hotspot) - 192.168.0.1;
- Subnet Mask - 255.255.255.0;
- Start IP Address (initial IP address range of the server)-192.168.0.102;
- End IP Address (the end range of the IP-address of the server) - 192.168.0.204;
- Click the “Apply” button to apply the entered settings.

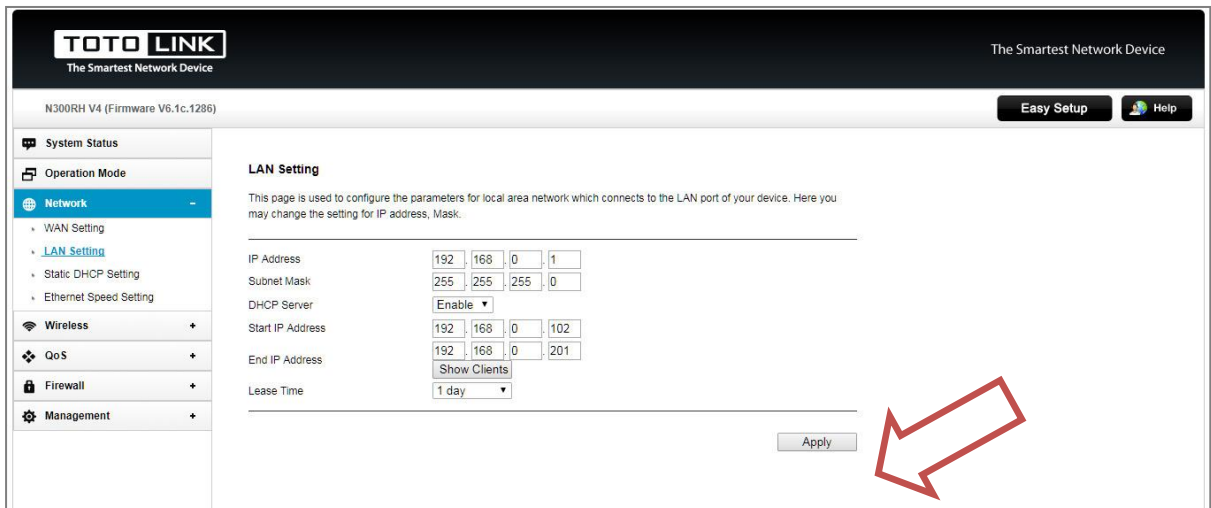

10. In the Wireless menu, go to the Basic Setting item and install:

- SSID (hotspot name) – LASERTAG²;
- Encryption - WPA2-PSK;
- Encryp Type - AES;
- Key (password to the hotspot) - 2015LT2015;
- Apply the selected settings using the “Apply” button.

² The equipment produced by the company allows up to 5 different names of Wi-Fi networks, each with its own password. Information on setting up can be obtained by contacting technical support.



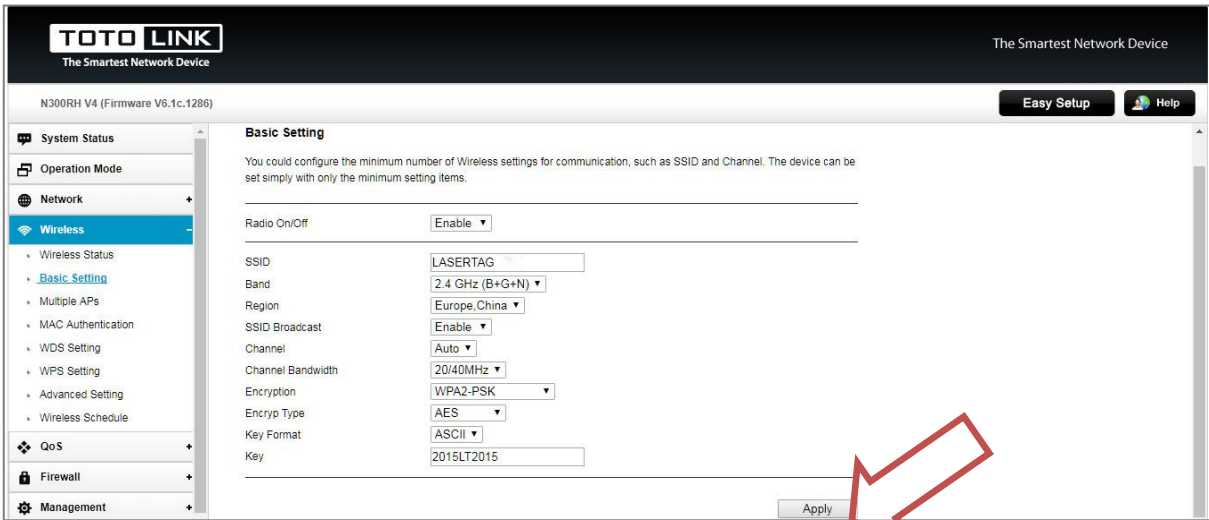

8. Portable power supply for the router

The full use of laser tag equipment involves the use of programs installed on a phone (tablet), and a router for connecting sets to the server via Wi-Fi. The router does not have an autonomous power supply, and the specificity of an external laser tag does not always allow you to plug it in.

In order to eliminate this disadvantage, the company supplies a portable power source (Power Bank) to the router.



Portable power supply

Portable power supply (PS) is designed to power electronic devices with a supply voltage of 5-12 V. Capacity for 12 V - 4,500 mA / h.

The PS is equipped with 2 USB outputs and one DC output (connector 5.5x2.1-2.5mm) with the ability to select the output voltage on it: 3.8, 6, 9 and 12 V.

The indicator panel is 4 LEDs that show the battery level when you briefly press the function button (25%, 50%, 75%, 100%). The indicator light turns off either by a double click or automatically after 10-12 seconds.

Holding the function button lights the LED lamp. Shutdown flashlight - double click on the button.

8.1. The procedure for connecting to the router

1. Set the 12 V voltage on the slide switch.



2. Connect the cord (male-male) with one jack to the DC output of the power source, and the other to the power connector of the router.
3. Check the operation of the router.
4. To turn off the router, you must remove the power cable.
5. To turn off the power supply, set the switch to the "OFF" position.

8.2. Charging the power supply

A separate IN jack with a micro USB connector is provided for charging the device. The supplied charger 5V 2A is used, powered by a common 220V network.

! Use only the original charger! Failure to do so may result in damage to the power supply and loss of warranty.

When charging the PS, you must follow the [safety rules for charging batteries](#) and [electrical safety rules](#).

! It is not recommended to leave charging equipment unattended!

During battery charging, lit LEDs show the current percentage of charge, and a blinking LED indicates that the charging process is in progress. The charging time depends on the degree of discharge and the condition of the batteries. On average, it is about 6 hours. When the battery of the power supply is fully charged, all indication LEDs are lit.

You must not try to charge the PS with the help of the charger for laser tag equipment with output voltage 8.4 V supplied by the company. It's OUT connector is the same as the DC output connector of the power source by design and size and improper connection may result in a device malfunction.

! When replacing or reinstalling the batteries built into the transmitter, carefully observe the correct polarity according to the markings in the compartment! Improper installation can lead to a short circuit of the board.



9. Charger 1A

The charger is designed to charge batteries built into the laser tag equipment. A feature of this device is that when the battery reaches full charge, the current automatically decreases, and the color of the charging indicator changes from red to green.

The rated value of the output voltage is DC 8.4 V. The maximum output current of one channel is 1A.

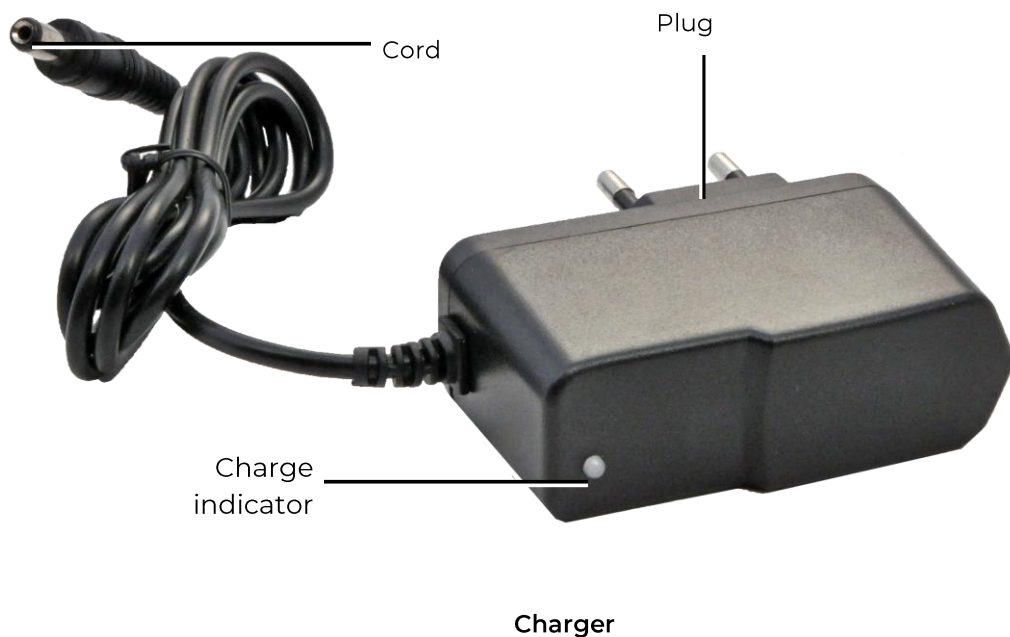

The equipment currently supplied by the company uses lithium-ion and lithium-polymer batteries rated at 7.4 V.

The charging cycle for fully discharged batteries is 5-6 hours for a headband (capacity 1500 mA / h), vest (1800 mA / h), tager, and additional devices (2600 mA / h).

When charging equipment, the safety instructions for charging batteries and electrical safety rules must be observed.

! It is not recommended to leave charging equipment unattended!



10. Charger 2A

The charger is designed to charge batteries built into the laser tag equipment. A feature of this device is that when the battery reaches full charge, the current automatically decreases, and the color of the charging indicator changes from red to green.

The rated value of the output voltage is DC 8.4 V. The maximum output current of one channel is 2A.

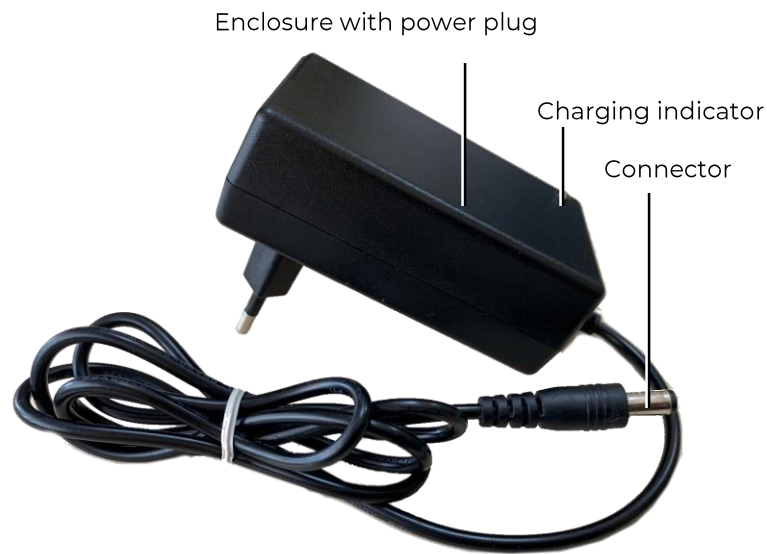

Charger

The equipment currently supplied by the company uses lithium-ion and lithium-polymer batteries rated at 7.4 V.

The charging cycle for fully discharged batteries is 2 hours 40 minutes for a headband and a vest, 2 hours for a laser tag gun and DBs, and 2.5 hours for a SIRIUS station.

When charging equipment, the safety instructions for charging batteries and electrical safety rules must be observed.

! It is not recommended to leave charging equipment unattended!



11. Charger Vortex

Charger Vortex is designed to charge 7.4 V lithium-ion batteries installed in laser tag equipment manufactured by the company.

The device allows you to simultaneously charge up to 20 pieces of equipment - laser tag guns, headbands or additional devices - from one 220 V electrical socket. Moreover, all the channels are independent, and the failure of individual boards does not affect the work of the others.



Overall device view

The rated voltage of the charger AC 100-240 V, frequency 50/60 Hz.

The rated value of the output voltage is DC 8.4 V. The maximum output current of one channel is 2 A.

Each channel of the charger has an electronic protection circuit that provides protection against overload and short circuits. Built-in two-color indicators show the charging mode. When the power is turned on, the LEDs turn green to indicate that they are ready for use. After connecting the charging device, the LED of the corresponding channel starts to glow red, and when it reaches full charge, the color of the indicator changes to green.

The charging cycle for fully discharged batteries is 2 hours 40 minutes for a headband and a vest, 2 hours for a laser tag gun and DBs, and 2.5 hours for a SIRIUS station.

When charging equipment, the safety instructions for charging batteries and electrical safety rules must be observed.



It is not recommended to leave charging equipment unattended!



12. Electronic shooting range

An electronic shooting range is intended, first of all, for adjusting collimator sights of tagers. In addition, the shooting range can be used both in the game scenario and as an independent attraction.

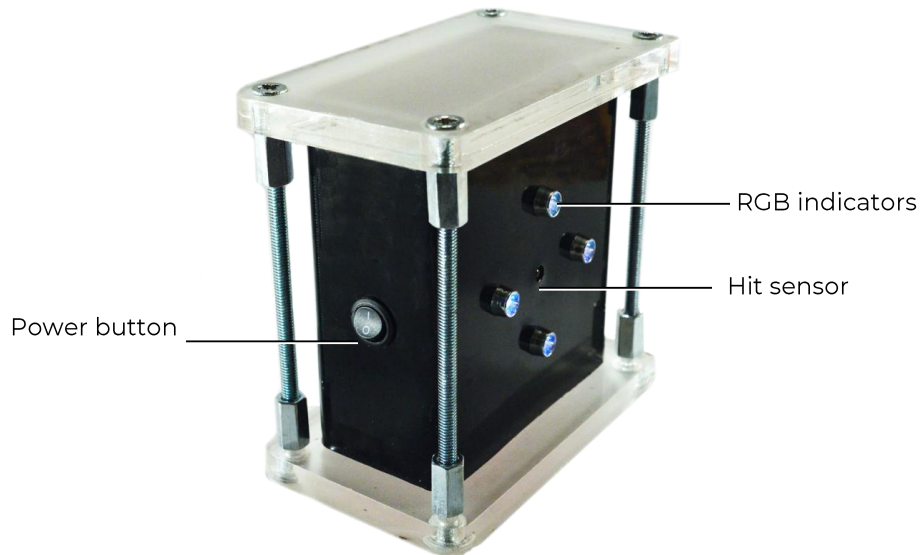

Electronic shooting range

On the body of the electronic shooting range, there is a power button, a connector for connecting a charger, an IR receiver, and four RGB hit indicators. Power supply - built-in Li-ion battery (7.4 V).

To use the device, you need to set it at the required distance (for shooting 60-80 m) and click the button . The LEDs will light up in white and the electronic shooting range will be ready for operation. With each infrared ray hit, the shooting range responds with a 2-second flash of the team's color of the shooting player and a piezoelectric sound signal, after which it again turns into a white glow.

The shooting procedure is as follows:

1. Install the shooting range on a stable surface, preferably at a height of 1.5-2 m.
2. Step back with a calibrated tager to a distance of 60-80 m.
3. Aim at the mark of the collimator and make 2-3 shots at the shooting range.

If you couldn't hit it, shoot lower, higher, on the sides. Remove the protective caps of the adjusting screws and adjust the sight.

4. Shoot again. Continue adjustment until it hits accurately.



13. Trip-wire mine

A trip-wire mine is suitable for many scenarios and can be used both indoors and outdoors. It is recommended to install at the entrance / exit of the building, in doorways, at turns, behind shelters, bushes, trees.

After its activation, the device using an ultrasonic motion sensor detects the player's crossing a sector with a radius of 4 meters and a capture angle of about 15°.

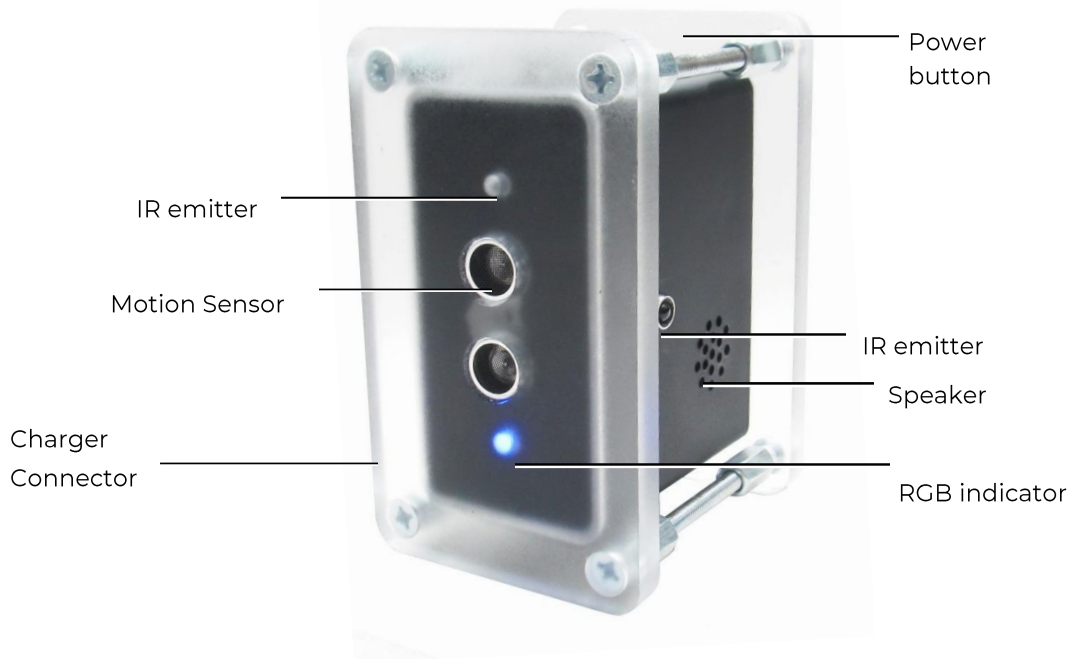

Trip-wire mine

There is a power button, a connector for a charger, a speaker, 2 ultrasonic motion sensors, an IR receiver (hit sensor), 5 IR emitters (on each side except the bottom one) and an RGB indicator are placed on the mine's body. Power supply - built-in Li-ion battery (7.4 V).

8.3. Planting

Planting tripwire mines is done by turning on the power button . After that, within 5-6 seconds (so that the player who plants it can move away from it) the mine activates the working mode. The transition is accompanied by an intermittent sound signal from the speaker on the side panel and a smooth change in the color of the glow of the RGB LED from red to green. When the diode goes out, and the sound signal goes silent, the mine is activated.

- ! **During the transition to the operating mode, there should be no players or any objects in the control zone of the mine-extension — in this case, either the mine control zone is reduced or the device does not activate: the sound signal does not stop, the LEDs blink repeatedly.**

After a player of any team crosses the control zone, the device reproduces the sound of the explosion and gives out 10 infrared signals within 3 seconds, striking players of any team within a radius of 10 meters.

Then the mine switches into the standby mode for 5 minutes. In this mode, the RGB LED fades in and out in blue. The standby timer is saved in the controller memory, i.e. if in the standby mode, turn off and turn on the mine, then it will not switch into the working mode.

After 5 minutes of the standby mode, a short signal is played and the LED starts blinking smoothly in red, which signals that the mine is ready for a new installation. Installation is done by turning the power off and on.

In order not to wait 5 minutes, the administrator can use the remote control to reduce the standby time. To do this, you need to direct the IR emitter of the remote control at the front panel of the mine and press the Start the Game button  - the standby timer will be reset. The LED will blink red smoothly and to set the mine, you must turn the device off and on again.

8.4. Mine clearance





On the front panel of the mine, there is a hit sensor, this allows you to deactivate it with well-aimed shots from the tager.

The number of shots for mine clearance depends on the set damage value per shot. If the damage to the weapon is less than 10, you need to shoot the mine hit sensor 16 times. With damage from 10 to 30 - 8 times, with damage above 30 - 4 times.

The interval between shots should be no more than 2 seconds. If, for example, after the 5th shot more than 2 seconds pass, then the shot counter will be reset to zero and the clearance process must be performed again.

The completion of mine clearance is accompanied by a short sound signal and the LED starts blinking smoothly in blue - the mine switches from working to standby mode. To reactivate the mine, you must either wait 5 minutes or use the Remote Control (press the "Start Game" button).

Summary table of the RGB-LED indication of the tripwire mine

Light color		Mode	Action
Smooth transition from red to green		Mine activation	After 5 seconds, switch to the operating mode
Smooth blinking in blue		Standby	Wait 5 minutes or stop the mode with the remote control
Smooth blinking in red		Readiness	To activate mines, turn the device off and on again
Is not lit		Working/Mine is off	When a player crosses a control zone a mine "explodes" / Turn on the device



14. Electronic grenade

The grenade is designed for use in laser tag games.

The grenade during the "explosion" emits only impulses of infrared light and is absolutely safe for players. Caution should be observed only when throwing not to cause injuries.



Electronic grenade

The device consists of a body made of PVC plastic, two rubber bumpers and an electronic device located inside the body. On one of the sides of the grenade there is a connector for the charger, and a control button. Inside the case there is an electronic control board, batteries, 2 LEDs, 6 IR emitters.

Power supply - 2 Li-Pol 603030 batteries - a total of 7.4 V, 480 mAh.

To activate a grenade, you must:

1. Take a grenade in your hand.
2. Press the button on the grenade. In this case, a single sound signal is reproduced by the speaker of the grenade, and the LEDs begin to glow with a steady red light.
3. Throw the grenade in the direction of the opponent.

! It is recommended to throw by "rolling" - approximately the same way as throwing balls in a bowling alley. Other methods like throwing, throwing at a player, throwing against a wall or an obstacle, can lead to injuries and/ or malfunction of the device.

The button is "goes out" and the timer starts. After 5 seconds, the grenade IR diodes send the "Delete the Player" command to all the kits within the infrared ray.

In order to make the search of the device easier, after its "explosion", the grenade switches to the "Search" mode. In this case, the LEDs blink and a sound signal is sent every 0.5 seconds. To force the grenade to turn off in this mode, you must hold down the control button until the LEDs turn off. If no action is taken, the device will automatically turn off after 2 minutes.

To throw again, repeat the activation algorithm.

Charging is carried out by a standard charger supplied by the company (nominal output voltage DC 8.4 V, maximum output current 1A).

Charging time - about 3 hours. In this case, it is necessary to observe the rules for charging lithium-polymer batteries.

15. Safety procedures

The components of the laser tag equipment supplied by the company are complex devices that require careful and accurate handling.

Do not allow moisture to get into the devices. If nevertheless it happened - quickly turn off the equipment and dry it for 4-5 hours at room temperature.

Take good care of the optical elements of the kit (collimator sight, tube lenses) - protect from mechanical damage and dirt. If dirty, wipe with special wet wipes.

Protect plastic equipment enclosures from excessive mechanical load. If the equipment was stored in a room with minus temperature, keep it warm for at least 2 hours before turning it on and use it in heated rooms. This measure is necessary to avoid damage to the electronic components due to condensation.

In the cold season, it is recommended to wear a headband over a hat. In hot weather - use a hygienic cuff, which should be replaced and sanitized after each game.

 **Do not use laser tag guns, especially similar to military weapons, for games outside the laser tag area! The reaction of passers-by and law enforcement agencies can lead to irreparable consequences.**

When using equipment with a built-in battery, observe the safety precautions for handling lithium-ion batteries.

The lithium-ion batteries used in our equipment have a number of advantages over traditional batteries. They are light in weight, have a long service life and a large specific capacity per unit mass and volume. Storage and operation batteries do not pollute the environment; they comply with all international environmental standards.

However, lithium-ion batteries also have disadvantages. One of the main ones is sensitivity to overcharging and overdischarging. Although every battery supplied by our company is equipped with an internal protection circuit, the safe handling of Li-ion batteries must be taken seriously.

Lithium-ion batteries have a very high specific energy. Be careful when using and testing them.

If the battery terminals are dirty, wipe them with a clean dry cloth before use. Otherwise, overheating of the contacts is possible when used in modes of increased current output.

Do not use the battery at high temperatures (for example, in direct sunlight, near a heat source or open flame) - overheating increases the gas pressure inside the battery, and this can lead to an explosion or at least shorten its service life. When the battery cools below 0°C, the power decreases to 40-50%. Maximum allowable temperatures at which lithium-ion batteries can be used: from -40°C to +50°C. But it should be noted that when the battery is cooled below 0° C, the power decreases to 40-50%, and with prolonged external heating above + 40° C, the self-discharge of the battery is significantly accelerated.

Do not use the battery under static electricity conditions - protection devices may fail and problems may arise in the safe use of the battery.

Do not squeeze, throw, pierce with sharp objects or expose the battery to other mechanical stress!

Do not disassemble the battery - it may become depressurized, overheat and ignite.

Do not short-circuit the positive and negative terminals of the battery with metal objects or wires.

When connecting multiple lithium batteries, use batteries from the same manufacturer - of the same rating, in the same technical condition.

Do not use the battery without an electronic protection circuit.

Do not reverse the polarity of the battery terminals.

Do not connect the battery to devices that are not designed to be powered by it.

Do not use bloated batteries - they must be replaced.

Do not immerse the battery in water, do not throw it in a fire - it may explode!

Do not solder the battery directly to the plane.

Do not bring the battery to a minimum charge. Frequent recharging is preferable - this does not harm the battery.

Charging a battery.

Use a ventilated and fire-safe room to charge the batteries. If the batteries could ignite, they can't cause a fire in the entire room.

Burning lithium-ion batteries cannot be extinguished with water (hydrogen is formed) and carbon dioxide fire extinguishers (lithium reacts with carbon dioxide). You can use dry sand, salt, baking soda, as well as cover the burning battery with a dense heat-resistant cloth. Therefore, we recommend storing sand near the battery charging point.

Do not charge non-rechargeable lithium batteries! An attempt to charge these devices can cause an explosion and ignition, which spread toxic substances.

! If the battery is damaged, do not recharge it!

Use only standard charger and origin batteries. Violation of this condition may damage the batteries and equipment, cause an electrical short, fire, create an explosion hazard, etc.

The temperature mode of the charge of lithium-ion batteries affects their capacity, which decreases when charging in the cold or in the heat. The charge can be carried out at an ambient temperature ranging from +4°C to + 40°C, but the optimum charging temperature is +24°C.

Before using the charger, check the correctness and quality of the connection of all wires. If any wires of the charger are damaged, they must be replaced before using the device.

When charging, install the equipment on a flat, stable, non-combustible surface. Remove nearby flammable objects.

When charging equipment with a built-in battery, the electrical safety rules must be observed.

It is not recommended to keep the battery charger in a power outlet if it is not being used for its intended purpose at this time.

When unplugging the device from the mains, unplug it from the power outlet by holding the plug, not the power cord.

! Do not leave equipment unattended while charging!

If a specific odor, heat, smoke is released when charging the battery, or the case is deformed, immediately disconnect the charger from the network, and the battery from the charging device.

The charging cycle for fully discharged batteries is 3 hours for a bandage (capacity 700 mA/h), and 5-6 hours for a laser tag gun (capacity 2200 mA/h). The battery is fully charged after the voltage reaches its maximum value, and the charge current decreases to 0.1... 0.07 A depending on the battery model.

If the cell swells when charging, then never puncture the element, especially when it is still hot. It should be placed in salt water and wait until the element cools down. After cooling, carefully pierce the outer shell, and then place the cell in salt water again. After that, the battery must be utilized.

In the event of an emergency, lithium cells may be damaged by short circuits inside. Moreover, the element itself may seem whole. In any case, it is better to remove the battery and watch it carefully for 20 minutes.

In case of depressurization of the battery and electrolyte contact with hand skin or eyes, immediately rinse the affected area with running water for 15 minutes and consult a doctor. Otherwise, it may cause a chemical burn, partial or complete loss of eyesight.

Storage and disposal of batteries.

Lithium-ion batteries are not subject to long-term storage and are designed for active continuous operation. From the moment of manufacturing, their service life is 2-3 years, regardless of the intensity of operation.

If there is a need to store unused batteries for more than 1 month, they must be charged up to about 50%. Long storage in a discharged condition can lead to battery failure.

Store at +5°C... +20°C (preferably +5°C) in a place protected from direct sunlight.

Do not store the battery in rooms with high temperatures or high humidity, or together with metal objects such as paper clips, hairpins, etc.!

Battery protection circuits have a low internal consumption, but nevertheless sufficient so that the battery voltage can decrease to 2.5 V in a few months. Therefore, if the battery is not used in cycling mode, it must be recharged periodically (about once every 6 months).

If during storage of the battery you notice that it is very hot, hissing gas escapes, the appearance of caustic white smoke, then immediately move it to a place safe for people. If electrolyte spills from the battery, do not allow it to come into contact with skin, ventilate the room, and dispose of the battery.

The lithium contained in Li-ion batteries melts and boils at a relatively low temperature. When water enters, a reaction occurs with the release of hydrogen. Accordingly, such a battery is potentially explosive during prolonged uncontrolled storage and can cause environmental damage.

In order to avoid undesirable consequences, the used elements must be collected and delivered to specialized recycling centers. Meanwhile, they are ought to be packed in such a way as to avoid electrical contact with the container or other battery. Pack leaking elements in such a way as to locate the leak. Use protective equipment: gloves, eye protectors, appropriate work clothing, a respirator, and sealed plastic bags.

 **Do not dispose of lithium-ion batteries in trash cans!**

Technical support contacts are listed on the company website
<https://lasertag.net/support/>



Parts 1 (Kits) and 3 (Software Setup) of the operating instructions for the outdoor laser tag are available for download here:
<https://lasertag.net/manuals/>

